

Available online at <http://www.mecspress.net/ijwmt>

PPLS: Personnel Presence Locator System – An Amalgam of RF Ranging & Zigbee in WSN

Syed Rameem Zahra^a, Mir Shahnawaz Ahmad^b

^a *Shri Mata Vaishno Devi University, J&K, India*

^b *Maulana Azad National Urdu University – ASCW, Budgam, J&K, India.*

Received: 23 March 2018; Accepted: 04 June 2018; Published: 08 July 2018

Abstract

In this day and age of occupied time plans, individuals are confronting numerous issues in following the employees and specialists in colleges, schools, universities, doctor's facilities and so forth, hence it ends up vital that each assignment is expert intelligently, productively and in an auspicious way. To achieve this, easy accessibility of people of interest is a must. To alleviate this problem, we propose a solution called "Personnel Presence Locator System (PPLS)" that is an internetworked amalgam of small systems working independently. Moreover, in this article, we give an overview of the naturally multidisciplinary writing of human-detection, concentrating essentially on the extraction of five regularly required properties: in particular Location, Count, Presence, Track, and Identity. The objective of this work is to uncover the abilities and constraints of existing solutions from different disciplines, to manage the production of new frameworks like PPLS and point toward future research bearings.

Index Terms: Personnel Presence Locator System, human-detection, location, presence, identity.

© 2018 Published by MECS Publisher. Selection and/or peer review under responsibility of the Research Association of Modern Education and Computer Science

1. Introduction

The most basic human-sensing applications perform functions such as, open an entryway as individuals pass, turn lights on/off when a room is in-use/vacant, or bolt a PC when the client moves away. However, that should not be the only importance of human-sensing applications as the functionality must be extended to answers like "who the person occupying the room is?", "who has visited him in the recent past?", "what are his body parameters at the moment?" etc. With this, the applicability of these human-sensing applications is enhanced

* Corresponding author. Tel.:
E-mail address: rameemzahra@gmail.com

and also it is indicated that the problem of human-sensing in itself is multi-faceted. Today, People mostly students and patients are finding it difficult to trace the instructors in universities and specialists in hospitals. After waiting for long hours, patients come to realize that the doctor isn't in the hospital or is in the theatre which implies that they need to sit tight for some additional time. So also, the helpful time of students is squandered while they search for their instructors in the school grounds. Radar and Computer Vision organizations have previously contributed solutions for such problems, while as in the recent times; Robotic researchers have proposed numerous solutions. This paper uncovers the progress made in each of these directions, the pros, and cons of each, and serves as a guide for the creation of systems of the future. By and by, there are frameworks which are Wireless Sensor network- based, however; they are utilized to discover the area of a solitary individual or a component rather than a system of the workforce as is proposed in this article. This paper presents the use of sensors for the detection of the location of different personnel in an organization creating a system called "PPLS" with the help of which one can easily locate any person working in an organization.

1.1. Human-Sensing Taxonomy

The inherently important properties of human-sensing are Presence → Count → Location → track → Identity. There is an inbuilt hierarchy among these properties as for example, the information about the count of individuals would itself imply their presence. In detail:

- **Presence:** Answers if at least one person is present. To detect the presence, most commonly deployed sensors are the scalar infrared rangefinders (e.g. Used for elevator door safety purposes), PIR motion sensors (e.g. Used for automated lighting purposes). In the application scenarios where people can be tagged with wearable devices, RFID solutions seem to be escalating. PPLS also makes use of RFID along with Zigbee for detecting the presence of individuals.
- **Count:** Tells the number of people that are present at a particular place. Commercially available solutions for counting people span from simple mechanical barriers such as turnstiles to thermal imagers and break-beams. PPLS can inherently count the number of people at a specific location.
- **Location:** Speaks about the area of occupancy of a particular individual. Instrumented and un-instrumented solutions have been proposed for achieving localization information. PPLS clearly indicates the location of each and every individual at any given point in time.
- **Track:** Tells where this person of interest was before being here. Track attempts to explore the spatiotemporal history of an individual. Our System "PPLS" is capable of tracking the personnel with ease.
- **Identity:** Reveals the uniqueness of each individual telling who is who. The combination of Zigbee and RFID makes it possible to identify each person with complete certainty.

PPLS thereby caters to all the required properties of a human-sensing application. The employed architecture is shown in figure 1.

1.2. Wireless Sensor Network

A Wireless Sensor Network (WSN) is a network which has either minimal infrastructure or just no infrastructure at all. Wireless sensor networks [1] have earned immense attention during the recent years for their enormously useful applications in both the fields of military and civilian importance [2]. A WSN can be of 2 types viz. Unstructured WSN and Structured WSN [3].

- **Unstructured WSN:** It is a WSN composed of a large number of sensing nodes (sensors) deployed in an ad hoc fashion. Once the network is deployed, it is left unwatched to carry out the functions of

observation and reporting. Since the number of nodes in this type of network is huge, therefore its maintenance is difficult.

- **Structured WSN:** Here the number of sensor nodes installed is very less compared to unstructured WSN and hence its maintenance is quite easy. Moreover, the entire deployment of sensing nodes is according to a plan. This type of WSN is cost efficient also.

WSN gives us the opportunity to implement what we think. Made up of nodes (hundreds to even thousands), WSN has each of its nodes connected to one or more than one sensor and helps us to access the data generated by these sensor nodes [4]. Every sensor has these two essential components viz. A radio transceiver and a power supply. An important application of Structured WSN in a civilian domain has been proposed in this paper, a system which keeps track of different persons working in a huge organization for quick accessibility. The uniqueness of PPLS lies in the amalgamated use of Radio Frequency ranging and Zigbee to cover an entire range of probable locations of the people in an organization. The locator systems which have been proposed in literature till date cater to specific areas such as sports, health etc. but our system, i.e. PPLS can be used in any type of an organization, incurring the minimum cost and infrastructural complexity.

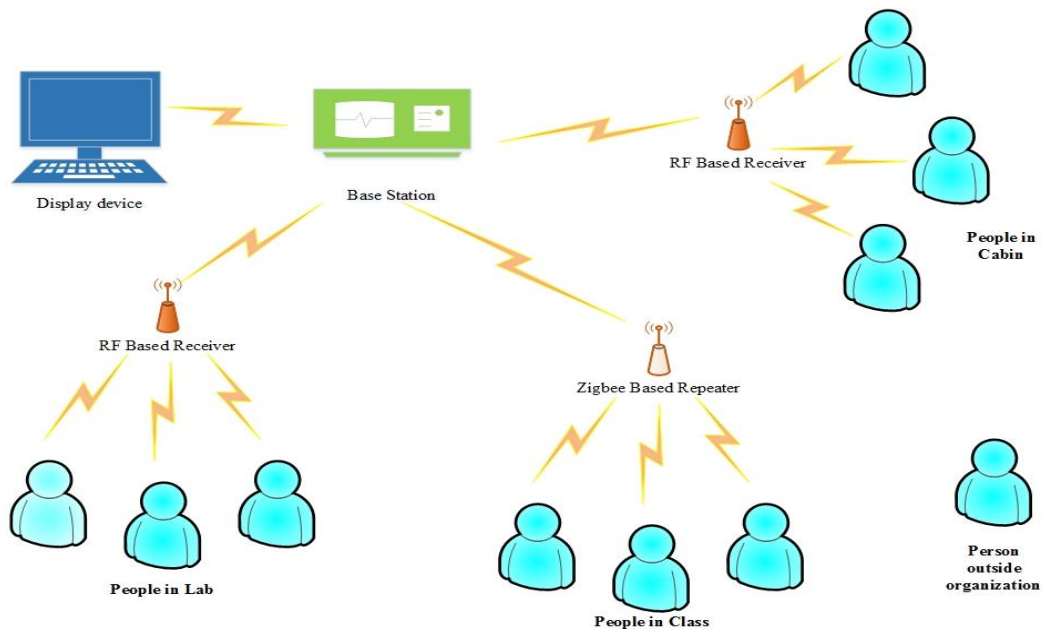

Fig.1. Architecture Diagram

1.3. Radio Frequency ranging

Radio Frequency (RF), infra-red and ultra-sound, are the 3 important types of indoor localization systems on the basis of physical transmission technology employed for the purpose of localization. The systems based on RF are more common because of the huge availability of extant wireless network infrastructure such as GSM, Wi-Fi [5]. Radio Frequency Ranging along with Zigbee has been used in PPLS to provide the communication between the transmitter-receiver pairs and the base station. The previous sensor network hardware systems would use optical transmissions [6] while as the sensor networks today employ RF communication. Both RF and optical types of communication have their own advantages and disadvantages like optical communication can be easily constructed by spending a small amount of money [7] and also the power consumed will be

comparatively low, nevertheless, the type of communication is not very flexible and cannot be used everywhere. One of the main issues (though not a big one, i.e. it can be resolved) while using RF in sensor networks is that it requires visibility and directionality. RF, however, is an easily understood technology and highly flexible. The signals transmitted using RF frequencies will enable the microcontroller to identify the node and its location. There are two types of radios which can be used by the sensors. The first type of radio employs Carrier Sense Multiple Access (CSMA) providing basic Medium Access Control (MAC), it operates in 315/433/868/916 MHz free band utilizing a bandwidth of 20–50 Kbps range. Its range lies within 300 m. The second type of radio uses the onboard antenna making sensors more handy and independent because no external antenna is needed. The range of this type is 125 m.

1.4. Zigbee

Zigbee-802.15.4 is a technical standard for a group of high-level communication protocols which are used to build the Personal Area Networks (PAN) for tiny and low power consuming radios [8]. Its working frequencies are 900-928 MHz and 2.4 GHz and utilize a channel bandwidth of 1 MHz. Its use can be seen mainly in Wireless PANs (WPAN) reaching 10-30m in usual applications and going to 100m in some others. The data transfer rates are 250Kbps. It is extremely productive when we discuss its energy utilization in that it devours just 1/4th of energy expended in Wi-Fi systems. ZigBee is an ad hoc networking technology beating other competing technologies in terms of power usage, complexity and price [9]. The essence of using Zigbee i.e. 802.15.4 is the operational and technological simplicity achieved without compromising scalability and commonness. There could be 64000 nodes in Zigbee based network [10] and each user can define 240 application objects which are part of Zigbee application. For security, it makes use of 128-bit Advanced Encryption Standard (AES) and CCB-CCM for network security. It defines the specifications at the network layer for star, tree and peer-to-peer network topologies and provides an outline for programming at the application layer.

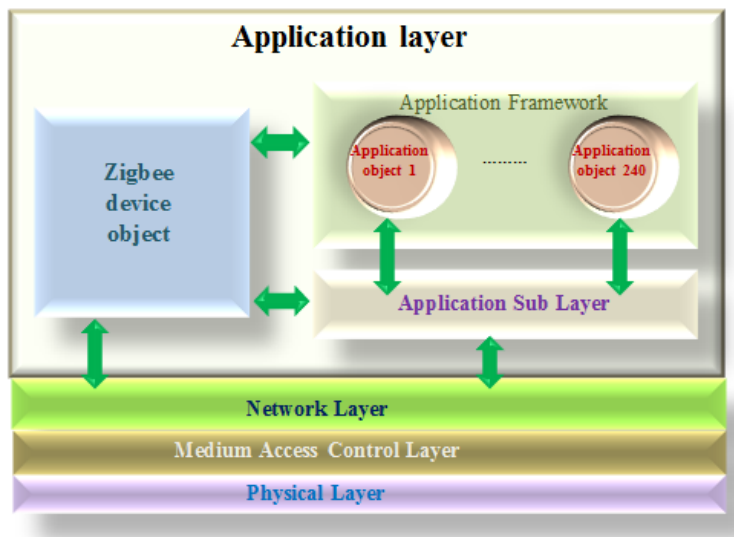

Fig.2. Protocol Stack for Zigbee

Albeit relatively comparative innovations like that of Zigbee exist (Wi-Fi, Bluetooth), we utilized Zigbee in PPLS for the accompanying reasons:

- Zigbee standard uses a quarter of power as used by the Wi-Fi based system. The devices using Wi-Fi 802.11 [11] require a very fine battery backup [12] even when they are to be used continuously for just 10 hours. On the other hand, Zigbee has been designed in the “assemble and forget” manner, i.e. they have extremely less appetite for power consumption and can run for months once installed. Also, Zigbee has been found to be 2.5 times more power efficient as compared to other competing technology i.e. Bluetooth. Therefore, by using Zigbee in PPLS, we cater to the demand of low power consumption, because it will become difficult as well as cost inefficient for a person in general or an organization, in particular, to change the battery every day.
- The quantity of gadgets which can be associated with a Bluetooth based system is only 8 while as in Zigbee based systems more than 64000 devices can be associated with each other. Consequently, Zigbee has been utilized in our Locator framework-PPLS on the grounds that there can be more than 8 likely areas for finding an individual in an association. Also, it is very easy to add, remove or move active nodes when Zigbee is used. Therefore, by employing Zigbee in PPLS, we are creating a network which is both flexible and extendable.
- By default, Zigbee based networks are ad hoc networks [13], they are laid without any planned design or code [14]. Also, Zigbee based networks are self-healing in nature, i.e. when a node gets damaged, its neighboring nodes will never send any information to it, thus preventing important information from being pushed to a damaged node. This is done by creating a reverting loop keeping the network always up and blatantly quite stable. Therefore, by using Zigbee we buy an integrated intelligence for network set-up and message routing.
- While Bluetooth network can only be established in point to point master-slave topology [15], Zigbee can be established in mesh, star, and other topologies. Since we have kept PPLS completely wireless, the topology of the network cannot be pre-decided; hence Zigbee is the best choice.

2. Related Work

The applications of WSNs can be classified into 2 types: Tracking applications and Monitoring applications. WSNs can be used to track humans, animals, things, vehicles, etc. Patient health and wellness monitoring, intra and inter-organization environment monitoring, seismic monitoring, machine monitoring, structure monitoring, inventory monitoring, water-level monitoring, power monitoring are some of the monitoring applications of WSN. Concentrating particularly on personnel localization, quite a few examples can be looked upon in literature, but the number of implemented solutions is almost zero. Some of the WSN based Location Tracking Systems which have been designed so far include Bagadus [16], CenWits [17], Mobile user tracking system with Zigbee [18] and AeroScout. Bagadus combine the use of camera array video capture and ZXY sport tracking system so as to get the statistics of the footballers. [16] Helps in determining the exact position of the player in the field, and thus his/her performance in the game can be evaluated by the coach. CenWits [17] Connectionless sensor-based tracking system using witness is a system for search and rescue application. CenWits employ many sensors based on radio frequency and few storage units along with processing devices. Here mobile sensors are worn by people of whose location we want to find out. The current location of the person is calculated using GPS receivers and location points. The information is also obtained from witnesses who give details about the movement of the subject of interest. [18] Provides the monitoring of groups visiting the historical buildings such as art galleries, museums, etc., allowing the automatic detection of individuals in various rooms of the historical buildings. This is achieved by using 4 types of Zigbee nodes working in coordination with each other viz. Zigbee Coordinator (installed in each and every room, collect the information from other nodes installed in a particular room and shares it with the base station system), Mobile Nodes (carried by the guides of various groups, provide the necessary information with the fixed nodes, which then transmit it to the coordinators), Fixed Nodes (two such nodes are installed in each room for tracking nodes which are mobile), Secondary Mobile Nodes (carried by all the individuals of the group). The entire tracking operation is done by using 2 protocols 802.11 (Wi-Fi) and Zigbee. Aeroscout (US) Company creates tags based

on 802.11b version of Wi-Fi (2.4GHz). The transceivers send the obtained information to base stations periodically after every 8 seconds. The basic idea and techniques used to implement context-aware computing was presented in [19], where the author provides detailed applications and techniques of using mobile computing for determining the context of different mobile users in a network. It also discusses how context-aware computing can be used in today's world. For context-aware computing we need to deploy a number of sensor nodes for sensing the current state of the surrounding environment, for the communication of these sensor nodes, radio frequency (RF) ranging method was presented in [20], which uses the shift in radio frequencies for detecting the state change in environment. To estimate the frequencies used by different mobile devices, Quinn and Hannan [21] provides many techniques for achieving the same. In 2005, a novel technique for healthcare monitoring was presented [22], which proposed the use of intelligent techniques for monitoring the health of remotely located patients by different body sensors by sensing the patient's health and then sending the collected details to remote doctors who can then advise the patients regarding their health issues remotely, thereby providing a smart health care monitoring of patients' health. Another technique which predicts the change in the health status of remotely located elderly people over a wireless link and consequently advises them how to remain healthy was presented in [23]. These novel techniques help user to understand how sensors can be used to sense the environment and its change. In 2000, Essa [24] presented a technique for sensing the environment using different sensors deployed in an environment. A complete mechanism for using Arduino in creating the electronic circuits was presented by Sarik and Kymissis in [25], which again helps us to understand how an Arduino can be used to manipulate the signals received by different sensors deployed for performing a special task.

2.1. Critical Analysis

The existing locator systems using PIR sensors cannot detect people who remain stationary or do not move too often, thereby giving a huge number of false negatives. Also, the final results that they give are vastly bursty. The problem with electric sensors is that their plates are extremely large as compared to other sensor types. Also, Electric Field Sensors demand high network density to provide accurate location details. Vibration sensors suffer from "Cocktail Party Problem" because, in the busy environments, a lot of interferences among individuals occur thus creating the problem. Doppler Sensors could be used for single person locating purposes like the search and rescue operations. The Locator systems which have been proposed till date use either of these sensors and are not generic. [16] Is typically a soccer analysis application. It uses Cordis Radio Eye receivers for tracking the football players on football grounds. Approximately 10 receivers are scattered on the ground for tracking all the 22 footballers, the update rate is 20 HZ. To achieve its goal [16] requires a complex architecture consisting of cameras, accelerometers, an analytical subsystem, a video subsystem. All of this costs too much and the architecture is complex. Also, CenWits was basically designed for emergency situations where search and rescue operation is needed. The system does not need to be connected every time. [17] Is basically meant for emergency situations and not for use within an organization where the system works continuously. The complexity of CenWits is also far higher than the system which we have proposed. Again, [18] services the need of historical buildings which require controlled entry to a particular room. It is meant for identifying the presence of groups inside rooms so as not to allow any more groups in that room and therefore cannot identify single individuals like PPLS. PPLS identifies each and every person of the organization as well as their location. The locator systems employing Aeroscout use Wi-Fi that has power limitations and hence not suitable for use within commercial organizations. The need arises to create a system which can be used in any type of organization, i.e. the one which is cost efficient, power efficient, can be used in any type of organization, has ease of installation, flexible and scalable. Hence, we have come up with a system for locating the personnel in any organization which we have called PPLS which is simple, easy to install, flexible and explained in detail in the upcoming sections.

3. Proposed System

Here, we detect the presence of a faculty member by using the sensor that works on the principle of radio frequency ranging. It consists of radio frequency (RF) receivers limited in the range of reception at various important places where the personnel have the maximum probability of being present. The person to be traced has a low power RF transmitter normally fitted anywhere like the keychain, wallet, pendant, bangle or any other ornament worn by the individual. Once the transmitter enters into the proximity of a particular receiver, the receiver receives the RF code and sends it to the base station. The base station consists of a code receiving unit, a processing unit, and a display unit. The processor takes a particular code from the code receiver unit and according to the algorithm displays the name of the area where the person of interest currently is, on the display. PPLS is designed by using 433MHz and 314MHz transmitter and receiver modules as RF sensors, Zigbee, Atmel Atmega328 microcontroller on Arduino prototyping board as processing module and a display as the information disseminator. Also, the display is fitted in a location where the masses can easily view it e.g. at the hospital entrance or a department lobby, etc. Hence anyone can find the person he/she is looking for with ease.

Table 1. Specifications of Instruments used

Instruments used	Specifications
Transmitter 315MHz/434MHz	Working voltage: 2.4V – 12V; Working current: 9mA – 40mA; Resonance mode: SAW; Modulation mode: ASK; Package: 4 pins; Range: 90 m.
Receiver 315MHz/434 MHz	Working voltage: 0.5V – 5V; Working current: 9mA – 40mA; Modulation mode: ASK; Package: 8 pins; Range: 90 m.
HT12E encoder IC	Working voltage: 2.4V - 12V; Low power and high noise immunity CMOS; Standby current: 0.1A at VDD = 5V; Package: 18 pins.
HT12Ddecoder IC	Working voltage: 2.4V - 12V; Low power and high noise immunity CMOS; Standby current: 0.1A at VDD = 5V; Package: 18 pins; Received codes checked 3 times.
Zigbee	Package: 20 pins; Operating voltage: 2.8V – 3.4V; Working current: 45mA Operating frequency: 2.4GHz; Security scheme: AES-128; Works in ISM band; RF data rate: 250,000 bps.
Arduino microcontroller Atmel Atmega 328	Operating voltage: 5V; Input voltage (recommended): 7V – 12V; Input voltage (limits): 6V – 20V; DC current for input/output pins: 40mA; DC current for 3.3V pin: 50mA; Digital i/o pins: 14; Analog input pins: 6. Package: 32 pins.

3.1. Base Station

The base station constitutes the backbone of the whole system and is a combination of different modules: A Power module, the Transmitter module, Repeater module, Zigbee module and the Processing module. All these components work together in order to process the received signals and finally transmit information about the location of a person to the display device. The circuit and block diagrams of the Base Station are shown in Figures 3 and 4 respectively.

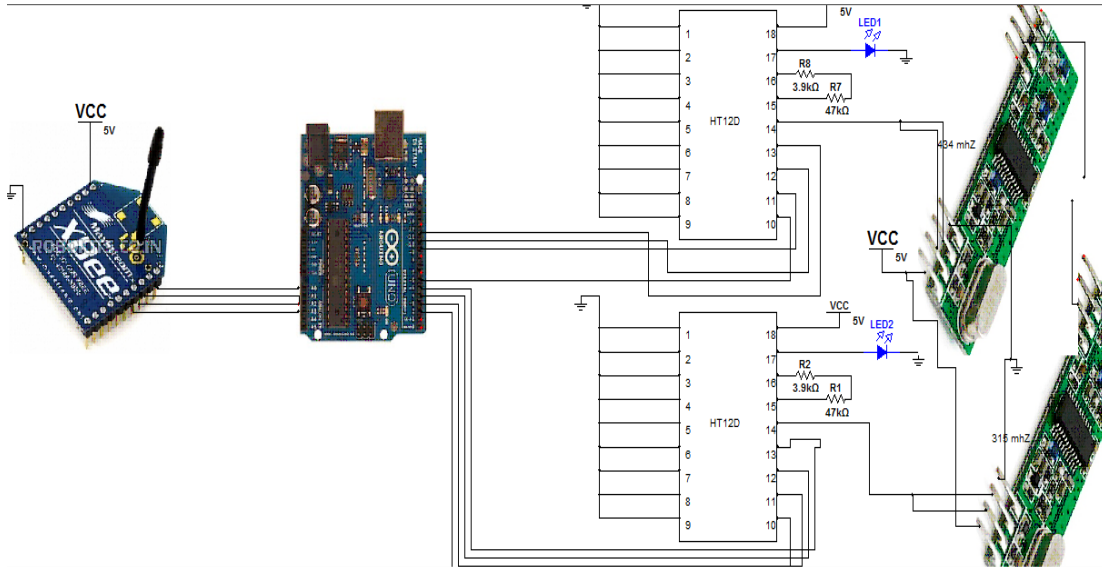

Fig.3. Circuit diagram of Base Station

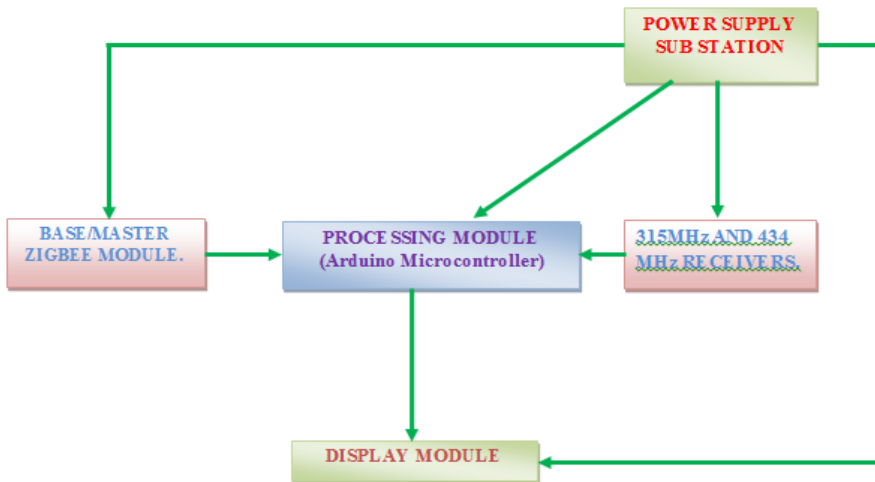

Fig.4. Block diagram of Base Station

3.1.1. Power supply module

The module which supplies electrical power to all the other connected electrical loads is the power supply module. Its main components include: a) the diode to allow the currents to pass in one direction only. b) A resistor to provide resistance wherever needed c) light emitting diodes to act as the indicators for various events d) electrolytic capacitors for noise and ripple elimination e) 1 micro-farad paper capacitors f) Three voltage regulators of the LM78XX series are used viz: 7812, 7809 and 7805 to provide regulated supplies of 12V, 9V and 5V respectively.

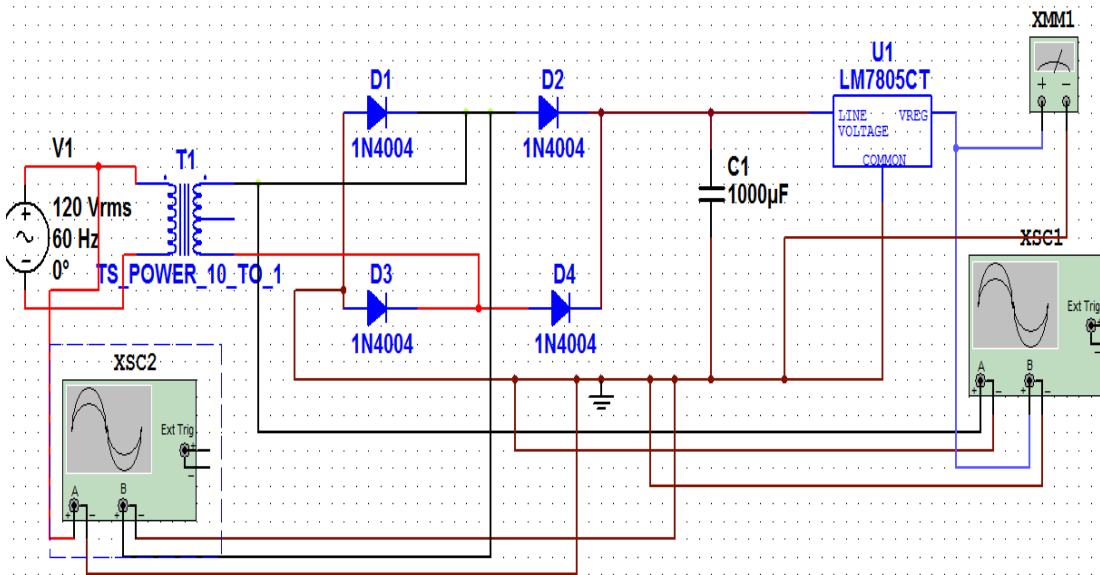

Fig.5. Circuit Diagram of Power Module

It can be clearly seen from the circuit diagram that a battery of 12V is connected to a resistor of 1K in series with LED through a diode. The diode is used to prevent the circuit from damage if the battery is connected in reverse polarity that can damage the regulators and electrolytic capacitors. The capacitors are used for elimination of ripples and noise. The regulated output is obtained across ceramic capacitors of 0.1 µf.

3.1.2. Transmitter module

A transmitter with the aid of an antenna generates radio waves. The transmitter with the support of an oscillator circuit produces a radio frequency alternating current (AC). This AC is handed over to the antenna which gives off radio waves. This emission is brought into use for the transfer of data to the receiver. We impress the information onto the radio frequency AC to be carried by the generated radio waves. At the point when these waves hit the receiver's antenna, they energize similar RF currents in it and subsequently the receiver extracts the impressed information from the received waves. The main purpose of the RF transmitter module in this system is that it is used to identify the person and his/her location, that is, a unique code is given to each individual. This particular code is sent by the transmitter carried by the person to the corresponding receiver and the receiver sends it to the base station. With the help of this information base station microcontroller finds out who the person and gives his/her location in the organization at that particular instant of time.

Table 2. Description of Transmitter Pins

Pin No.	Name	Function
1	GND	Ground (0V)
2	DATA	Serial Data Input
3	Vcc	Supply Voltage (5V)
4	ANT	Antenna Output

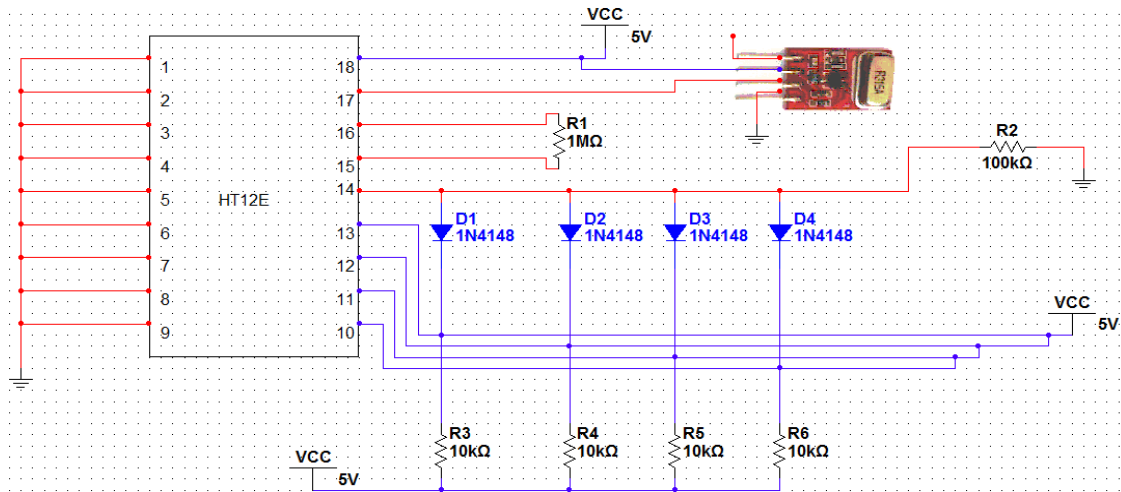

Fig.6. Circuit Diagram of Transmitter Module

The main components of the transmitter module are: HT12E, 1N4148 diodes, and 1 Mega Ohm oscillator. HT12E is mainly used for interfacing RF & infrared circuits and encodes 12 bit parallel data into serial to transmit it over RF transmission. Out of these 12 bits, 8 are used as address bits and 4 are used as data bits while as the combination of 1N4148 diodes and 10 KΩ resistors is used to get the Transmission Enable pin (T.E) of the HT12E IC low whenever some data is coming to the pins 10,11,12,13 of the encoder because it is only when T.E is low that data is accepted by the IC and put in the buffer wherefrom it is given out serially to the transmitter connected to the pin no 17 of the encoder HT12E IC. 1 Mega Ohm oscillator forms HT12E’s internal oscillator that is, the rate at which the data would be sent out to the transmitter via pin no 17 of the Encoder IC HT12E. These transmitters actually form the sensors of PPLS because they provide the necessary information required to decode the location information of people working in a particular organization to the receiver modules which then send it to the base station. At the base station, the information obtained is decoded according to an algorithm and the area where the person is located is displayed on the display board.

3.1.3. Repeater module

This module consists of two elements: RF transmitter, 434MHz and 315 MHz receivers. The transmitter acquires the data via its data pin and then transmits it via the antenna pin. The rate of this transmission is 1Kbps-10Kbps. The data sent by a transmitter operating at a particular frequency can only be received by a receiver working at the same frequency; therefore the data transmitted by a 315 MHz transmitter will only be received by a 315MHz receiver. For the reason of achieving scalability, these transmitters and receivers are often used with encoder/decoder pairs. The encoder takes parallel data; the reception is decoded by a decoder.

The receiver receives the data/information via its antenna and with the help of the decoder IC, HT12D data is sent out in a parallel fashion. However, the receiver in PPLS can give its output to one of the 3 things depending upon where the person actually is at the moment:

- To the 434 MHz transmitter: In case the faculty member is in Area1 (Laboratory). In Lab, a 434 MHz transmitter and 315 MHz receiver form a simple repeater module that helps in carrying the data further to the base station. Now on the base station, which in our case is located in area2- e.g. the cabin, is attached a 315 MHz receiver that is, if a faculty member is in the cabin the 315 receiver of the base station would directly accept the signal and the same information would be displayed on the display screen, but if the faculty member happens to be in the lab then we need to have a mechanism to give us that information. We cannot use a 315 MHz receiver directly in the lab as well because then there would be a conflict about whether the person is in the cabin or the lab. Hence we have a 434 transmitter attached to the 315 MHz receiver in the lab which acts as a repeater. The 315 MHz receiver gives its output to 434 MHz transmitter which is accepted by 434 receiver on the base station and hence the correct location of the faculty member (Lab) is displayed on the screen.
- To the Arduino / base station: As discussed above, this is the situation where the person is present in the cabin. Here the output of 315 MHz receiver is directly fed to the Arduino.
- To the remote ZigBee: In case the faculty member is in area3 (say a classroom) or any other area except area1 and area2, we use a ZigBee module. Here the output of the 315 MHz receiver is fed to the remote ZigBee, which communicates this information to the base ZigBee connected to the base station.

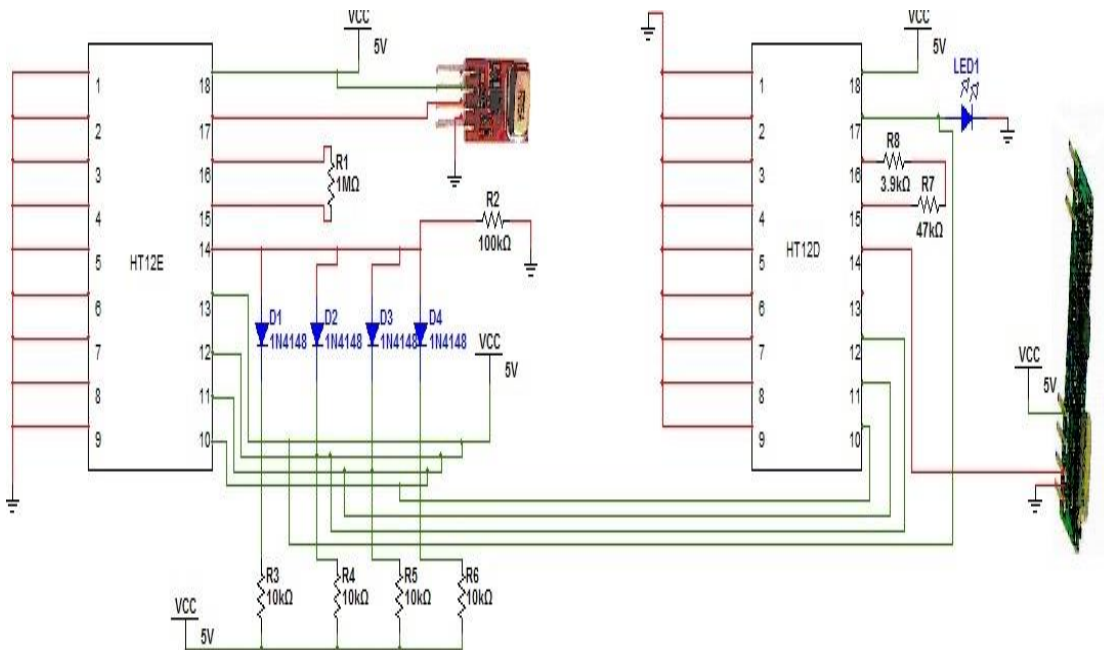

Fig.7. Circuit Diagram of Repeater module (434 MHz transmitter & 315 MHz receiver)

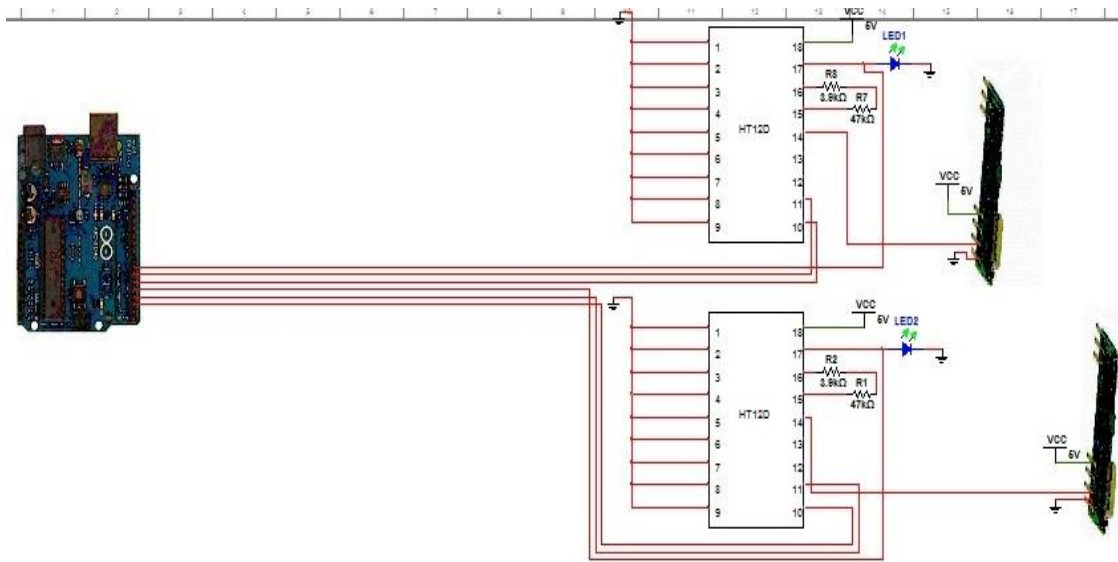

Fig.8. Transmitter near the base station-no repeater needed

The main component of a receiver is HT12D, which is used to convert the serial input into parallel output. It belongs to the 212 series of decoders. It is capable of decoding 12-bits, 8-bits are address bits and 4 are data bits. Also, a legit transmission is shown by a high signal at VT pin. The data on the data pins remains same until the new data is received.

3.1.4. Zigbee Module

In this system, Zigbee has been used to enable the use of more than 2 different locations where a person can most probably be found. This was not possible with the earlier used repeater module for the reason that we have used only 2 frequencies 315 MHz and 434 MHz and thus cannot use a third place for localizing a person as the frequencies would then interfere. To avoid such a chaos we make use of Zigbee, which proves to be the simplest solution to this problem. Such a combination of RF ranging and Zigbee has never been proposed to date. There happens to be one base Zigbee in every product and then any number (up to 65000) of nodes (remote Zigbees) could be attached to this base Zigbee. These remote Zigbee units then determine the location of the person. In this module, we simply use a different power supply and a transmitter. Remote Zigbee gets the information from the transmitter which it sends to the base Zigbee from where it is forwarded to the microcontroller which helps in displaying the exact location of the person in the organization.

Table 3. Configuration on Remote & Base Zigbee

Remote Configuration	Base Configuration
DL = 0x1234	DL = 0x5678
MY = 0x5678	MY = 0x12345
D0 = 2	P0 = 2
D1 = 2	P1 = 2
IR = 0x14	IU = 1
IT = 5	IA = 0x5678 (or 0xFFFF)

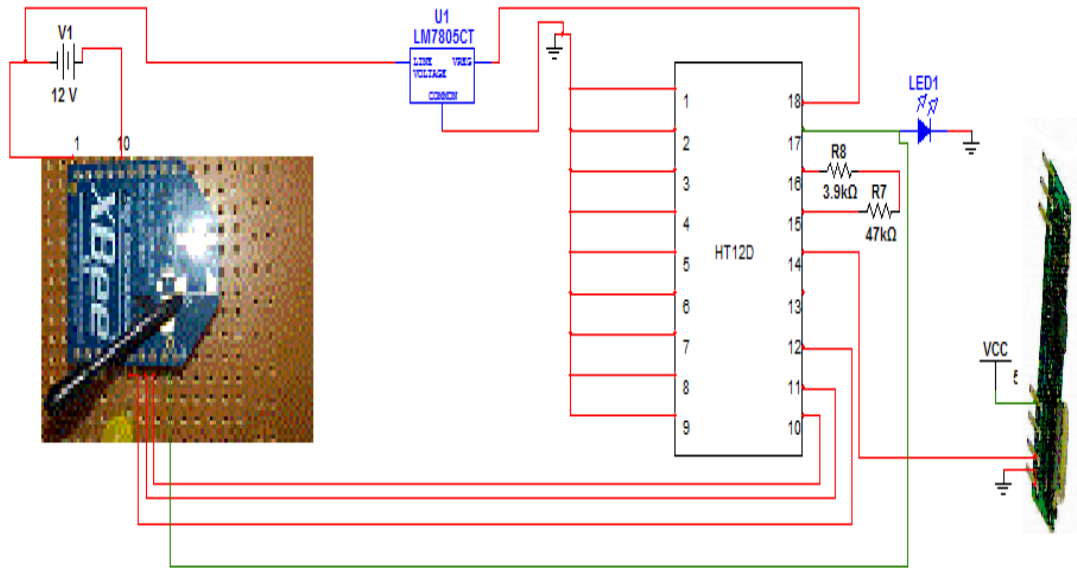

Fig. 9. Circuit Diagram of Zigbee Repeater Module

The settings given in table – 3 configure the remote module of Zigbee so that it samples AD0 and AD1 once every 20 ms. The remote Zigbee itself buffers 5 samples each and then sends them to the base Zigbee module. The base Zigbee should then receive a 32-Byte transmission (20 Bytes data and 12 Bytes framing) every 100 ms.

3.1.5. Processing module

The processing module used in our product i.e., PPLS is Arduino UNO, the driving force behind which is the ATMEGA-328 microcontroller. Arduino UNO is an open-source physical computing platform based on a simple microcontroller board and consists of a development environment where one can write software for the board. It takes input from various switches, sensors and thus can control various physical output devices. It can work in a standalone manner or can be integrated with a software snippet. Arduino is inexpensive, open source hardware and Arduino software can run on many operating systems (like Windows, Macintosh OSX, and Linux). The power supply can be given either through USB or external power supply to the Arduino and can operate on a supply of 6 to 20 volts. The ATMEGA 328 has a memory size of 32 KB and has 2 KB of SRAM and 1 KB of EEPROM [26]. It can retain data for 20 years operating at a temperature of 85 °C/ 100 years at a temperature of 25 °C.

The microcontroller ATMEL ATMEGA 328 is programmed using the Arduino software (an offshoot of Java). An algorithm loaded inside the microcontroller evaluates who the person is and where he/she currently resides and sends the information to the display. The entire working of PPLS around the base station is given in figure – 10.

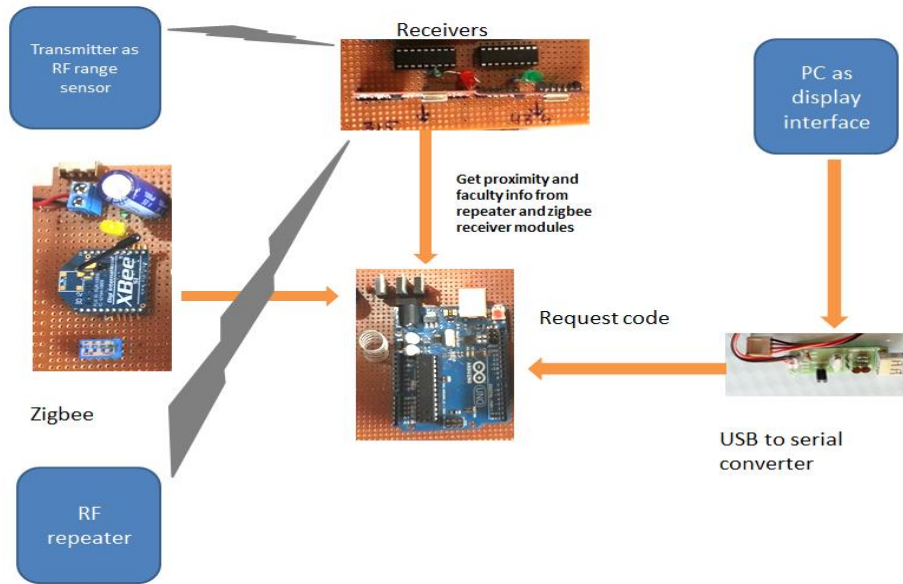

Fig.10. Working of Base Station

Algorithm on microcontroller Atmel Atmega 328

Input: Output of base station receivers.

Output: Message to Display.

1. Initialize all the variables in the microcontroller.
2. If signals received on pins 3,5,6,7, then
 - a. The receiver receiving information is 434MHz i.e. the person currently operating at the location where the repeater is fitted.
 - b. Evaluate the name of the person using the 4-bit code received on input pins of the microcontroller.
 - c. Send this evaluated name and location to the display device.
3. If signals received on pins 8,9,10,11, then
 - a. The receiver receiving information is 315MHz i.e. the person currently operating at the location where the repeater is fitted.
 - b. Evaluate the name of the person using the 4-bit code received on input pins of the microcontroller.
 - c. Send this evaluated name and location to the display device.
4. If signals received on pins A0, A1, A2, A3, then
 - a. The receiver receiving information is Master Zigbee i.e. the person currently operating at the location where one of the base Zigbee is fitted.
 - b. Evaluate the name of the person using the 4-bit code received on input pins of the microcontroller.
 - c. Send this evaluated name and location to the display device.
5. Repeat the above steps for each signal received by the microcontroller.
6. If the signal is not received from any of the input pins of the microcontroller, then the person is outside the organization.
7. End.

The Master Zigbee and the slave Zigees are synchronized with each other, so the master Zigbee knows exactly the location of slave Zigbee currently sending the information to Master Zigbee.

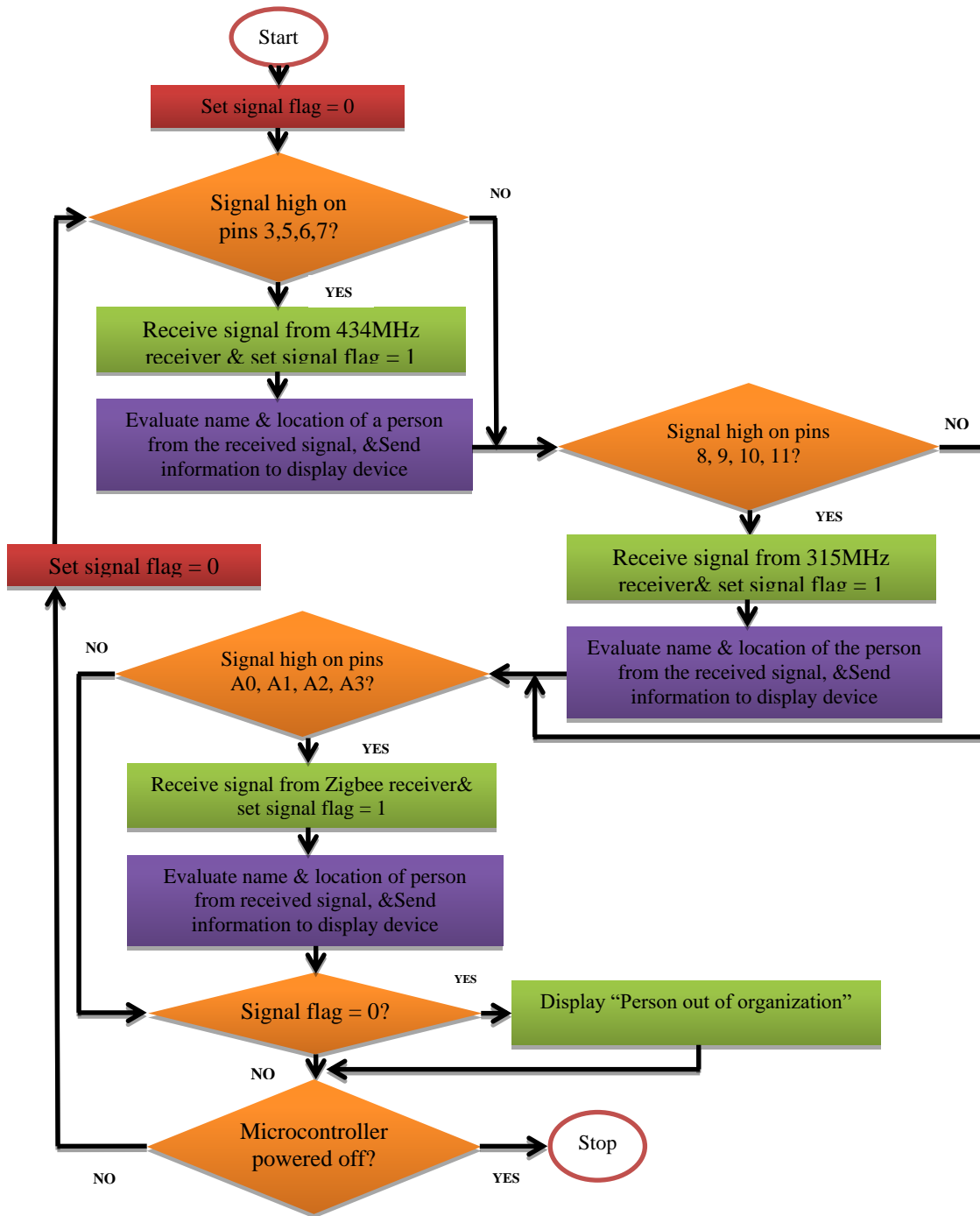

Fig.11. Steps Followed by Microcontroller to Process Received Signals

4. Results

PPLS was implemented practically and the following results/observations were noted:

It was noted that PPLS can be used in both Resource-constrained and Performance-driven environments. The complete system was deployed in the university campus, where the system detected the location of different faculty members who carry the transmitters with them. The results were noted and verified for exactness by comparing them with the actual location of faculty members. On comparison the results were exact. Therefore, PPLS detects the exact location of personnel in an organization, is able to count, identify and track them using RF ranging and Zigbee. PPLS is one unique solution to the problem of locating personnel in an organization because it is cheap, scalable, has less infrastructural complexity, makes the combined use of Zigbee and RF and is easy to implement. The efficiency of PPLS can be evaluated from the fact that the exact location of each and every faculty member present within the university campus was given.

5. Conclusions and Future Work

A high tech circuitry model capable of locating a person was presented in this paper. A software named as X-CTU was used to program the Zigbee units.

When huge scale human-sensing will be omnipresent, an unavoidable point will be that of privacy protection. Plainly, to make utilization of various services, individuals must forego different levels of privacy and security. For example, a taxi-calling administration essentially requires the client to share his area. In any case, individuals don't hope to give their date of birth, their photo, or a blood pressure reading only to utilize the taxi-calling service. In this manner, there will be a push for new human-sensing arrangements which can just concentrate on some specific properties, and which are — by the plan — unfit to measure anything else. There will be an expanded interest in privacy saving sensing equipment and in addition to new information portrayals that pack the estimation space and sift through touchy information.

References

- [1] I.F. Akyildiz, W. Su, Y. Sankara subramaniam, E. Cayirci, "Wireless sensor networks: a survey", *Computer Networks*, vol. 38, issue 4, pp. 393–422, 2002. DOI: 10.1016/j.comnet.2008.04.002.
- [2] Ravichander Janapati, ch. Balaswamy, K.Soundararajan, "Enhancement of Indoor Localization in WSN using PSO tuned EKF", *I.J. Intelligent Systems and Applications*, issue 2, pp. 10-17, 2017 MECS. DOI: 10.5815/ijisa.2017.02.02.
- [3] Jennifer Yick, Biswanath Mukherjee, Dipak Ghosal, "Wireless sensor network survey", *Computer Networks*, vol. 52, issue 12, pp. 2292–2330, 2008. DOI: 10.1016/j.comnet.2008.04.002.
- [4] G. Amato, P. Baronti, S. Chessa, "MaD-WiSe: programming and accessing data in a wireless sensor network," *International Conference on Computer as a Tool (EUROCON 2005)*, pp. 1846–1849(2005). DOI:10.1109/EURCON.2005.1630339.
- [5] Alessandro Redondi, Marco Chirico, Luca Borsani, MatteoCesana, Marco Tagliasacchi, An integrated system based on wireless sensor networks for patient monitoring, localization and tracking, *Ad Hoc Networks*, vol. 11, issue 1, pp.39-53(2013). DOI: 10.1016/j.adhoc.2012.04.006.
- [6] Chris Karlof, David Wagner, Secure routing in wireless sensor networks: attacks and countermeasures, *Ad Hoc Networks*, vol. 1, issue 2-3, pp. 293-315 (2003). DOI: 10.1016/S1570-8705(03)00008-8.
- [7] Rayan A. Alsemmeari , Sheikh Tahir Bakhsh, Hani Alsemmeari, "Free Space Optics Vs Radio Frequency Wireless Communication", *I.J. Information Technology and Computer Science*, issue 9, 1-8, 2016 MECS. DOI: 10.5815/ijitcs.2016.09.01.

- [8] Paolo Baronti, Prashant Pillai, Vince W.C. Chook, Stefano Chessa, Alberto Gotta, Y. Fun Hu, Wireless sensor networks: A survey on the state of the art and the 802.15.4 and ZigBee standards, *Computer Communications*, vol. 30, issue 7, 1655–1695(2007). DOI: 10.1016/j.comcom.2006.12.020.
- [9] Y.Wu, P.A.Chou, S.-Y. Kung, Minimum-energy multicast in mobile ad hoc networks using network coding, *IEEE Trans. on Communications*, vol. 53, no. 11, pp. 1906-1918, (2005). DOI: 10.1109/TCOMM.2005.857148 .
- [10] Negar Jadidkar, Hossein Samimi, Improvement of ZigBee Using by Thread and Backpressure Algorithm, *I.J. Wireless and Microwave Technologies*, issue 5, 1-13, 2017 MECS. DOI: 10.5815/ijwmt.2017.05.01
- [11] Izaz Ali Shah, Shahzeb Hayat, Ihtesham Khan, Imtiaz. Alam, Sadiq Ullah , Adeel Afridi, “A Compact, Tri-Band and 9-Shape Reconfigurable Antenna for WiFi, WiMAX and WLAN Applications”, *I.J. Wireless and Microwave Technologies*, Issue 5, 45-53, 2016 MECS. DOI: 10.5815/ijwmt.2016.05.05.
- [12] P. Bonnet, A. Beaufour, M.B. Dydensborg, and M. Leopold, Bluetooth-Based Sensor Networks, *ACM SIGMOD*, vol. 32, no. 4, pp. 35-40 (2003). DOI: 10.1145/959060.959067.
- [13] Y. Wu, P. A. Chou, and S.-Y. Kung, Minimum-energy multicast in mobile ad hoc networks using network coding, *IEEE Transactions on Communications*, vol. 53, no. 11, pp. 1906-1918 (2005). DOI: 10.1109/TCOMM.2005.857148.
- [14] Y. Wu, V. Stankovic, Z. Xiong, and S.-Y. Kung, “On practical design for joint distributed source and network coding,” *IEEE Transactions on Information Theory*, vol. 55, no. 4, pp. 1709-1720, (2009). DOI: 10.1109/TIT.2009.2013016.
- [15] Nick Baker, Zigbee and Bluetooth- Strengths and Weaknesses for Industrial applications, *IEE Computing & Control Engineering Journal*, vol. 16, issue 2, pp. 20-25 (2005). DOI:10.1049/cce:20050204.
- [16] Simen Saegrov, Alexander Eichhorn, Jorgen Emerslund, Hakon Kvale Stensland, Carsten Griwodz , Dag Johansen, Pal Halvorsen, Demo: Bagadus an integrated system for soccer analysis, *IEEE International Conference on Distributed Smart Cameras (ICDSC)*, Oct. 30 2012-Nov. 2 2012, Hong Kong, pp. 1-2(2012).
Link:http://ieeexplore.ieee.org/xpl/login.jsp?tp=&arnumber=6470164&url=http%3A%2F%2Fieeexplore.ieee.org%2Fxppls%2Fabs_all.jsp%3Farnumber%3D6470164.
- [17] J.H. Huang, S. Amjad, S. Mishra, CenWits: A sensor-based loosely coupled search and rescue system using witnesses, in: *Proceedings of the Third International Conference on Embedded Networked Sensor Systems (SenSys '05)*, San Diego, CA, 2005, pp. 180-191(2005). DOI: 10.1145/1098918.1098938
- [18] Jacek Stępień, Jacek Kołodziej, Witold Machowski, Mobile user tracking system with ZigBee, *Microprocessors and Microsystems*, volume 44, July 2016, pp. 47–55.DOI: 10.1016/j.micpro.2016.02.007.
- [19] Andy Harter, Andy Hopper, Pete Stegglesand, Andy Ward, Paul Webster, The anatomy of a context-aware application, *Proceedings of the 5th annual ACM/IEEE international conference on Mobile computing and networking*, pp. 59-68(1999). DOI: 10.1145/313451.313476.
- [20] BranislavKusy, AkosLedeczi, XenofonKoutsoukos, Tracking mobile nodes using rfdoppler shifts, *Proceeding, SenSys '07 Proceedings of the 5th international conference on Embedded networked sensor systems*, PP. 29-42(2007). DOI: 10.1145/1322263.1322267.
- [21] B.G. Quinn, E.J. Hannan, *the Estimation and Tracking of Frequency*, Cambridge University Press, (2001). DOI: 10.1017/CBO9780511609602.
- [22] Giuseppe Amato, Stefano Chessa, FabrizioConforti, Alberto Macerata, Carlo Marchesi, Health care monitoring of mobile patients, *ERCIM News No. 60*, January (2005). Link: http://www.ercim.eu/publication/Ercim_News/enw60/amato.html.
- [23] B.G. Celler, T. Hesketh, W. Earnshaw, E. Ilsar, An instrumentation system for the remote monitoring of changes in functional health status of the elderly, *IEEE International Conference IEEE-EMBS*, New York, 1994, pp. 908–909(1994). DOI: 10.1109/IEMBS.1994.415207.
- [24] I.A. Essa, Ubiquitous sensing for smart and aware environments, *IEEE Personal Communications*, vol. 7, issue 5, pp. 47-49 (October 2000). DOI: 10.1109/98.878538.

[25] John Sarik, IoannisKymissis, Lab Kits Using the Arduino Prototyping Platform, 40th ASEE/IEEE Frontiers in Education Conference, 27-30 October, 2010, Washington, DC, IEEE (2010). DOI: 10.1109/FIE.2010.5673417

[26] Link;<http://www.atmel.com/images/Atmel-8271-8-bit-AVR-Microcontroller-ATmega>

Authors' Profiles



Syed Rameem Zahra received the B. Tech. degree in Computer Science and Engineering from the University of Kashmir, Srinagar, J&K, India, and the M. Tech. degree in Computer Science and Engineering from SMVDU, Katra, J&K, India. She is currently pursuing the Ph.D. degree with the department of Computer Science and Engineering, National Institute of Technology Srinagar, J&K, India. Her area of research is Wireless Sensor Networks, Database Systems, VANETs and IoT Security.



Mir Shahnawaz Ahmad received the B. Tech. degree in Computer Science and Engineering from University of Kashmir, Srinagar, J&K, India, and the M. Tech. degree in Computer Science and Engineering from SMVDU, Katra, J&K, India. He is currently working as Lecturer at Maulana Azad National Urdu University – ASCW, Budgam, J&K, India. His main research focus lies in MANETs, WSN, Database Systems, Software Defined Networks, IoT and Data Sciences.

How to cite this paper: Syed Rameem Zahra, Mir Shahnawaz Ahmad, " PPLS: Personnel Presence Locator System – An Amalgam of RF Ranging & Zigbee in WSN", International Journal of Wireless and Microwave Technologies(IJWMT), Vol.8, No.4, pp. 78-95, 2018.DOI: 10.5815/ijwmt.2018.04.06