

Gas Leakage Detector and Monitoring System

Yekini N. Asafe

Yaba College of Technology, Lagos Nigeria

Email: Nureni.yekini@yabatech.edu.ng

Adigun J. Oyeranmi

Yaba College of Technology, Lagos Nigeria

Email: ranmi.adigun@yabatech.edu.ng

Oloyede A. Olamide

Yaba College of Technology, Lagos Nigeria

Email: mydgs@gmail.com

Akinade O. Abigael

Yaba College of Technology, Lagos Nigeria

Email: asafe2012@gmail.com

Received: 14 May 2022; Accepted: 21 July 2022; Published: 08 October 2022

Abstract: Leakage of gas is a major issue in the industrial sector, residential buildings, and gas-powered vehicles, one of the preventive methods to stop accidents associated with gas leakage is to install gas leakage detection devices. The focus of this work is to propose a device that can detect gas leakage and alert the owners to avert problems due to gas leakages. The system is based on a microcontroller that employs a gas sensor as well as a GSM module, an LCD display, and a buzzer. The system was designed for gas leakage monitoring and alerts with SMS via an Arduino microcontroller with a buzzer and an MQ2 gas sensor. The circuit contains a Microcontroller MQ2 gas sensor, buzzer, LCD display, and GSM module, when the sensor detects gas leakage it transmits the information to the Microcontroller while the microcontroller makes a decision and then forwards a warning message to the user as SMS to a mobile phone for decision to be taken accordingly. The output of this research will be significant in averting problems associated with gas leakages now and in the future.

Index Terms: Gas Leakages, GSM module, Gas Leakage Detector, Gas Sensor, GSM module.

1. Introduction

Gas leakage is a major problem within the industrial sector, residential premises, and gas-powered vehicles like CNG (Compressed Natural Gas) buses and cars where the use of gas has become an important source of energy (STET, 2012) to the aforementioned area in this era. The issue of Liquefied Petroleum Gas leakage has been so disastrous that it has resulted in serious harm, including the loss of life and property worth millions of dollars around the world. The catastrophic pipeline explosion has happened in different parts of Nigeria in that resulted into death and injury of many people and loss of property [1].

Gas is the most commonly used fuel in Nigerian homes and industry in which some required measures have to be strategized in order to protect against incidents and accidents such as suffocation and explosion associated with its usage. LPG is a highly inflammable gas made up of a mixture of butane (C₄H₁₀) and propane (C₃H₈) through buthylene and propylene and another hydrocarbon present in small quantity, due to the odorless of these chemical ethyl mercaptans is added as an odorant to give a powerful scent so that when leakage occurs it can be perceived [2], however in a situation of the minimum quantity of gas leakage, some people have a poor sensing ability to perceive and so, more reliable and effective device use in detecting gas (gas leakage detector) has to be installed in homes, industries, and vehicles of LPG usage to avoid explosion. LPG leakage refers to several factors such as leakage in the pipe, hose not properly fixed, and hearing of whistling or hissing sound around the cylinder, valve not fitted properly.

There are different ways of detecting gas leakage in which there has been existing LPG detector which only sounds out an alarm when there is leakage and there is still improvement that could be made to the existing ones, in which a microcontroller activates the alarm and sends a message through SMS to the appropriate personnel. The crux of the paper is to create a device that can detect LPG leakage as part of a safety measure and automatically send an SMS to the appropriate personnel and will activate an alarm immediately after gas leakage is detected in order to prevent wastage of

the gas and also explosion which could lead to damaging of properties and other calamities [3]. The focus of this work is to design a system that monitors gas leakage in an enclosed system using an Arduino Uno microcontroller and an alarm system are used to alert people within leakages neighborhood while SMS will be sent to the premises owner or safety organization to towards making decision to avert damages and loss of lives/properties. The objectives among others if the design is implemented are:

- i. To prevent loss of lives and properties when gas leakages occur
- ii. To enable prompt action by the premises owner and safety organization towards avert problems that may be associated with gas leakages.
- iii. To enable people around the gas leakages premises take action to prevent damages escalation.

2. Literature Review

This section presents the review of some studies that are related to gas leakages detection.

2.1. Liquid Problem Gas Detection

Liquid problem gas is a flammable mixture of hydrocarbon gases used as fuel in heating appliances, cooking equipment, and specifically as a vehicle fuel (it is often referred to as autogas). It is an odorless gas due to ethyl mercaptan is added as an odorant to be easily detected when leakage occurs for safety precaution. LPG is made by refining petroleum or wet natural gas and is almost entirely derived from fossil fuels sources being manufactured during the refining of crude oil as theory emerged from the natural state. It was classified as a hazardous material because of its explosive potentials when under pressure, due to this hazardous property leading to fire explosion. The gas detection process was made by the chemically infused paper that change its color when it's been exposed to gas before the development of the electronics gas detector. The electronics leakage detector was an active approach to initial fault detection in other to achieve the utmost safety of humanity and properties as a whole they introduced an android base automatic gas detection).different approaches have been used alongside several research in the detection of leakage and were also implemented alongside some incident toward some decades. The existing leakage detection is optical sensor method, cable sensor, negative pressure, vapor sampling, signal processing, mass volume, and pressure point analysis, in which have been implemented using a different framework. Some groups of researchers have classified the technology as two fitting categories, which are software and hardware method but research continues and to technical nature research effort which led them to three group methods [4].

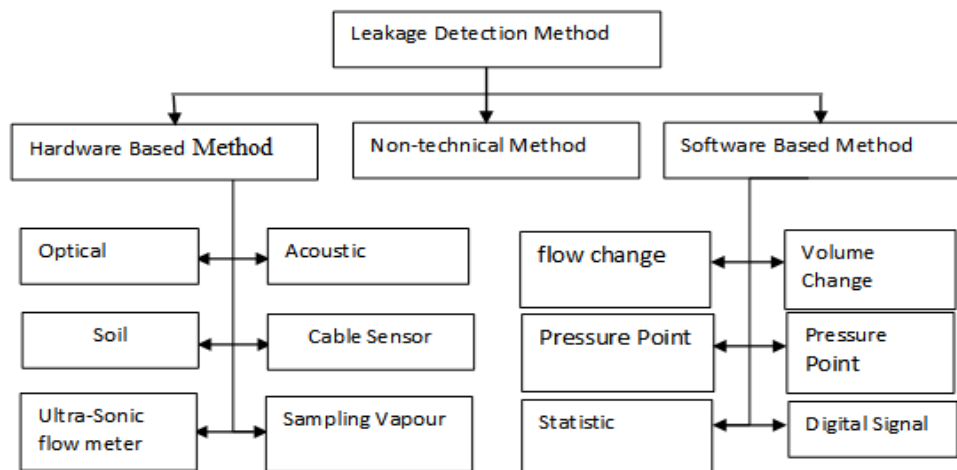

Fig. 1. Gas Leakage Detection Method Based on Technical Nature

2.2. Classification of Leakages Detection

There are different classes of leakage detection which have been used to monitor the leakage, several criteria are classified into their classification, some of which are critical principles and abilities needed from humans. The detection is classified into three, which are automated detection, manual detection, and semi-automated detection. Automated Detection involves monitoring of detecting leakage without the help of the operator, once the detector device is installed and been connected to the display of the personnel in charge and can be automatically shut down from the display unit. (SCADA); Manual Detection - These are methods in which the device can only be operated by humans. Like thermal imager or light detection and ranging (Lidar) devices; Semi-automated detection – solutions that necessitate a certain amount of input or assistance in carrying out certain tasks (e.g. statistical or digital signal processing methods) (Batzias et al., 2011). The technology used in leakages detection can be classified into two categories which are, Direct method

and the Indirect method The direct method is making use of a handheld detector by the patrol team along the pipeline and in the aspect of the very long pipeline, the airplane mounted optical imaging device is used along the pipeline for measuring gas emanation for fast result [5,6].

2.3. *FPGA-GSM Based Gas Leakage Detection*

In the work entitled FPGA-GSM Based Gas Leakage Detection Method by [7]. They investigated a simple FPGA-based system that detected LPG leakages using the MQ6 sensor. In the event of gas leakage, an automatic warning call is sent to the first response team via GSM to avoid any delays. There is no remote monitoring or any mechanism for mitigating gas leaks, such as automatic shut-off of the gas supply.

2.4. *Embedded Real-Time System For Gas Leakage Detection*

A domestic applications in residential buildings for an Embedded real-time system for gas leakage detection in which sensor nodes are installed in various households and communicate with a single central node. An alarm is triggered in the event of gas leakage. The concerned personnel is identified and alerted via text messages using the assigned MAC address of the RF module in each sensor unit. The use of exhaust fans is a commonly proposed solution for gas-related accidents, however, this system is only capable of mitigating a possible disaster and not completely averting it, since this approach reduces the risk by expelling gas leakage instead of shutting down the supply [8,9].

2.5. *Wireless modularization of gas safety devices.*

Smart home gas safety management system based on wireless modularization of gas safety devices was designed to allow safety in the homes in other to reduce damages. The system is based on the commercially available intelligent Micom meters, which have enhanced standard gas meters with a built-in microcontroller and a cutoff valve. The system is primarily concerned with detecting fire breakouts, and the existing gas meter has been upgraded to communicate with an external smoke and CO detecting sensor, as well as fire extinguishing modules, which are used to extinguish the fire when the temperature exceeds the threshold. The requirement for an existing Micom meter to construct the enhanced gas and fire safety method is a disadvantage of this system, as it lacks independent application. [10] developed a gas leakage detection and location system based on wireless sensor networks. They used wireless sensor networks to detect gas leakages and ensure product safety in the petrochemical industry. The system emphasizes the importance of developing centralized location software by collecting data from wireless RF sensors in order to precisely pinpoint the location of gas leakage and aid in the response time reduction In spite of the absence of remote monitoring and automatic shutoff, the study emphasizes the importance of inter-node communication in developing a dependable leakage detection system [11].

2.6. *Automatic Safety Gas Stove and liquefied petroleum gas booking and monitoring*

An automatic safety gas stove that uses Infrared (IR) sensors to detect the presence of utensils on the stove. In the absence of utensils, the system relies on motors to turn the stove knob to turn off the gas supply. The system presumes that the gas leak is limited to the stove burner and ignores the possibility of a leakage in the gas supply pipe. Its ability to detect gas leaks is limited due to the absence of any sensing units. The disadvantage of this approach is that it does not take into account scenarios such as gas pipe leakage [12]. Automated Unified System For LPG Using Microcontroller And GSM Module: This was a very cost-effective automated liquefied petroleum gas booking and monitoring, which the gas leakage is detected through the weight sensor to detect the level of the gas in the cylinder and an MQ series sensor to monitor leakage through the SMS received by the user and automatically book the cylinder. It also involves an exhaust fan that is switched on and a solenoid valve fitted to the cylinder to close once there is leakage [13].

3. **Methodology Materials and Design**

The proposed system will use an Arduino microcontroller detector system to sense the gas with the help of a sensor. In which the MQ2 sensor used in this system interfacing with Arduino is implemented in this project and the signal from the sensor is sent to the microcontroller which is connected to communicate with the LCD, send a signal to the buzzer to sound an alarm when there is leakage and also send a message through the GSM module. The GSM module is a piece of hardware that connects to a remote network, this does not involve an internet or hotspot wifi which makes it more recommendable than the IOT leakage method which has could fail due to network failure and unaffordable equipment to low-income earners and also has a quick response gas leakage. In this research work, the hardware component to be used is Arduino Uno Micro-controller, GSM Module (SIM800), MQ2 Gas sensor, Buzzer, Power Module, Stripped Vero board, Female and Male Pin header, OLED Display, 3D printed case, Power Switch, LEDs, connectors, and Lithium Polymer Rechargeable Battery. The proposed diagram is model as figure 2.

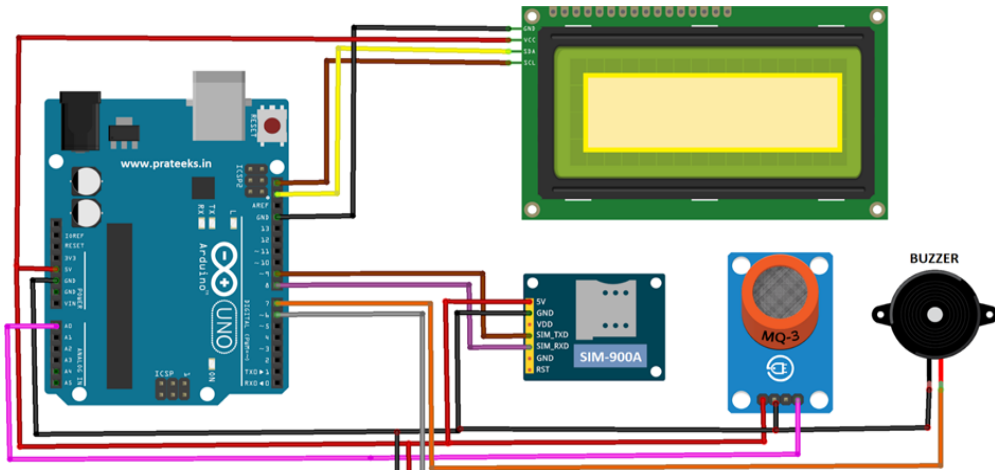

Fig. 2. Block diagram of the proposed project

The operational mode of the proposed is depicted with flowchart figure 3.

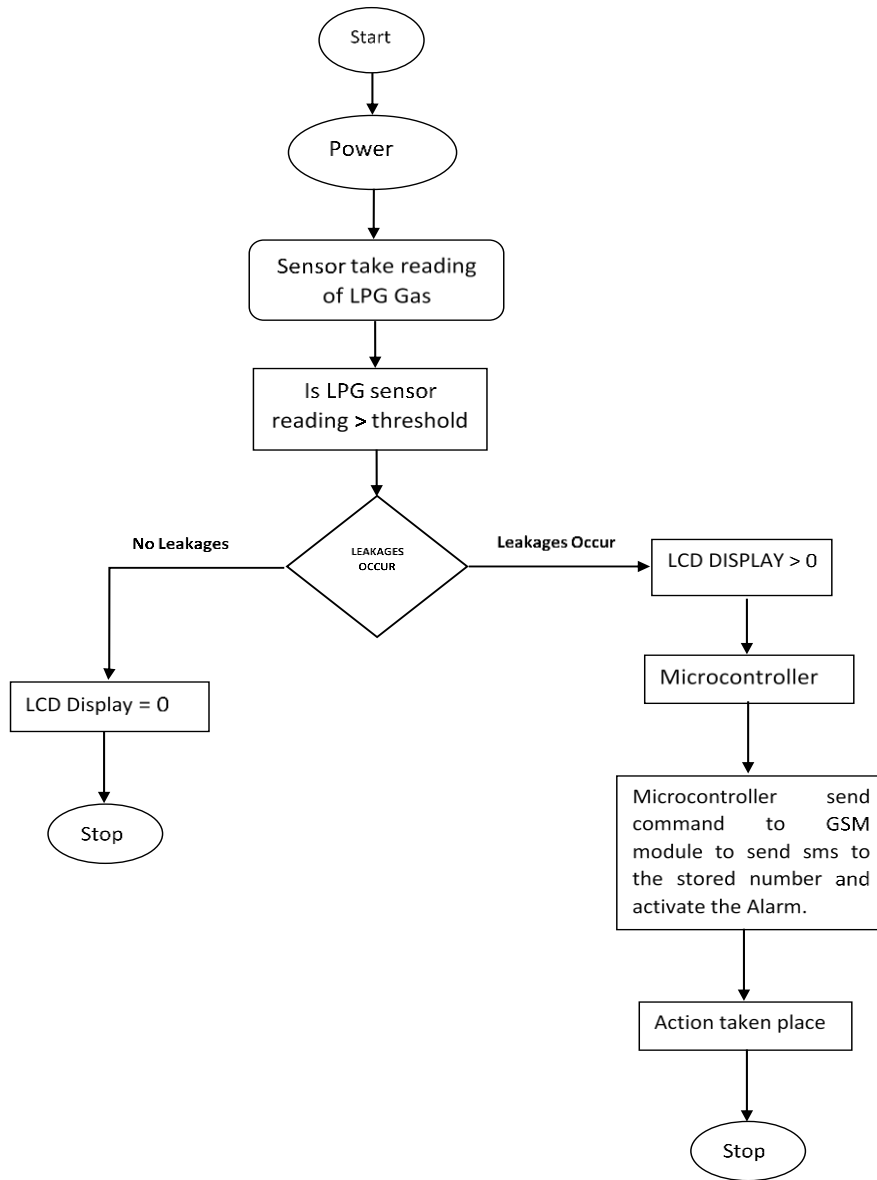

Fig. 3. Operational mode of the proposed System

4. Implementation

4.1. Construction

Stage 1: Circuit

The first stage of the hardware construction was to put together all the components using a stripped Vero-board, the components were soldered to the circuit board and all connections were tested before proceeding to the next stage as seen in the diagram below.



Fig. 4. Circuit on circuit board

Stage 2: Computer-Aided Design

The next stage was to design the device's casing using Computer-Aided Design (CAD) software, iTeam decided to use Fusion 360 as it is easy to use and has a free version. The entire device was designed, but the main focus was the enclosure that would later be 3D Printed. After designing the enclosure, the model was exported and sliced using CURA which is slicing software that prepares and generates code from a 3D model that can be sent to a 3D printer. Finally, the Model was printed.

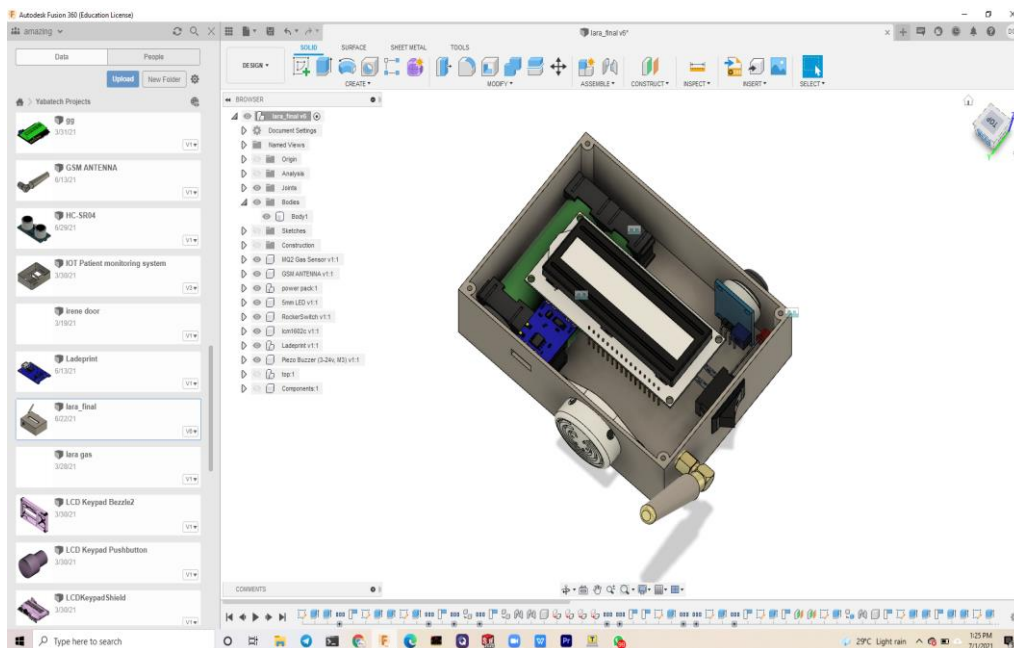

Fig. 5. Design on Fusion 360



Fig. 6. Finished Rendered Design

Stage 3: Assembling

After printing the device casing, we assembled the circuit and other components inside the case ensuring it fit well.

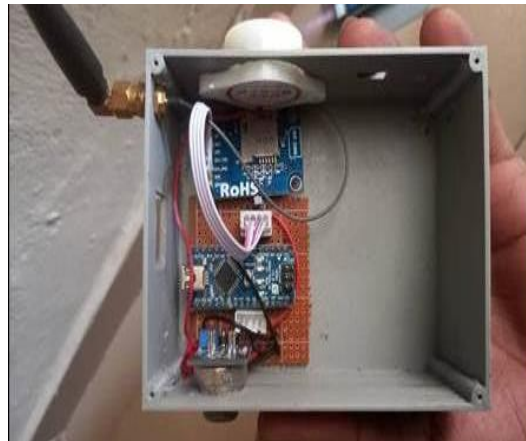

Fig. 7. Fixing of the Components in the Casing



Fig. 8. Prototype of the proposed system

Software Design

The hardware was coded using C++ on Arduino IDE, and the pseudo code is as shown as follows.

```
#include <SoftwareSerial.h>
#include <Wire.h>
#include <LiquidCrystal_I2C.h>
LiquidCrystal_I2C lcd(0x27, 16, 2);
//Create software serial object to communicate with SIM800L
SoftwareSerial mySerial(2, 3); //SIM800L Tx & Rx is connected to Arduino #3 & #2
int smoke_sense = 210;
```

```

void send_sms(String msg)
{
  mySerial.println("AT+CMGF=1"); // Configuring TEXT mode
  updateSerial();
  mySerial.println("AT+CMGS=\"08051230116\"); //change ZZ with country code and xxxxxxxxxxxx with phone
number to sms
  updateSerial();
  mySerial.print(msg); //text content
  updateSerial();
  mySerial.write(26);
  updateSerial();
  delay(6000);
  mySerial.println("AT+CMGF=1"); // Configuring TEXT mode
  updateSerial();
  mySerial.println("AT+CMGS=\"08051230116\"); //change ZZ with country code and xxxxxxxxxxxx with phone
number to sms
  updateSerial();
  mySerial.print(msg); //text content
  updateSerial();
  mySerial.write(26);
  updateSerial();
}
void updateSerial()
{
  delay(500);
  while (Serial.available())
  {
    mySerial.write(Serial.read()); //Forward what Serial received to Software Serial Port
  }
  while(mySerial.available())
  {
    Serial.write(mySerial.read()); //Forward what Software Serial received to Serial Port
  }
}
void setup()
{
  lcd.init();
  // Print a message to the LCD.
  lcd.backlight();
  lcd.setCursor(3,0);
  lcd.print("FALCON");
  lcd.setCursor(2,1);
  lcd.print("ROBOTICS");
  delay(2000);
  //Begin serial communication with Arduino and Arduino IDE (Serial Monitor)
  Serial.begin(9600);
  pinMode(A0, INPUT);
  pinMode(7, OUTPUT);
  //Begin serial communication with Arduino and SIM800L
  mySerial.begin(9600);
  lcd.clear();
  Serial.println("Initializing...");
  delay(1000);
  mySerial.println("AT"); //Once the handshake test is successful, it will back to OK
  updateSerial();
  lcd.setCursor(2,0);
  lcd.print("loading.....");
  delay(3000);
  lcd.clear();
}
void loop()
{

```

```

Serial.println(analogRead(A0));
if(analogRead(A0) > smoke_sense)
{
digitalWrite(7, HIGH);
lcd.setCursor(0,0);
lcd.print(" SMOKE/GAS  ");
lcd.setCursor(0,1);
lcd.print(" DETECTED!! ");
send_sms("Alert! Alert!, Smoke/Gas Detected at your Apartment!");
delay(1500);
digitalWrite(7, LOW);
}
else
{
lcd.setCursor(0,0);
lcd.print(" ATMOSPHERE  ");
lcd.setCursor(0,1);
lcd.print(" CLEAR  ")
}
}
}

```

Stage 4: Testing

Finally, the device was tested by using a gas to simulate flame to ensure everything was working fine and it did.



Fig. 9. Screen short for testing of the proposed system

5. Conclusion

This work presents the design and implementation of gas leakage detection system. Various works on gas leakages detection system was reviewed and presented. I was discovered that some of the existent research don't takes in to considerations the cost effectiveness for the purpose of implementation of gas leakages detection at individual/domestic uses, and not easy to be further modified. This research work had advanced in knowledge as it included an embedded system to alert users via multiple mobile phones for further action to be taken when leakage is detected. The device detects gas leakage using a highly sensitive MQ-2 gas sensor to activate a buzzer that alert people of leakages, and also sent an SMS with the information "Gas Leakage Detected" from the SIM800 GSM Module as a backup to alert the appropriate authority or facility owner of a gas leakage. This design could be adopted, funded, and implemented as it has a great potential of mitigating against accidents associated with LPG leakage.

References

- [1] Punch newspaper 2021, Panic as gas leakage occurs in Ikeja. Available at <https://punchng.com/breaking-panic-as-gas-leakage-occurs-in-ikeja> retrived January 17, 2021.
- [2] A., L. (2017). *Wireless gas leak detection improves employee protection, environs, and production value.*
- [3] Arpitha, T. K. (2016). FPGA-GSM-based gas leakage detection system. Bangalore. *IEEE Annual India Conference (INDICON)*, 1-4.
- [4] Chengjun, D. X. (2011). Development of gas leak detection and location system based on wireless sensor networks. Shanghai. *Third International Conference on Measuring Technology and Mechatronics Automation*, 1067–1070.
- [5] Kareem, H. (2019). Embedded real - time system for detecting leakage of the gas used in Iraqi kitchens. *Indonesia J. Elect Eng Comp Sci .vol 14*, 1171-1176.
- [6] Loth, J. M. (2003). *Technology Assessment of online Acoustic monitoring Leak In fragment in the underground, natural gas Transmission Lines.* USA: West Virginia University.
- [7] Manohar, R. a. (2018). *Android Introduction to Detection.* Hindu: Nwebweze, O. (December 2015) vanguard News .com .
- [8] Murvaya, P. (2011). A survey in Gas leak Detection and localization technology. *Journal of loss prevention in the Process Industries*, 11-25.
- [9] Park, G. L. (2013). Development of gas safety management system for smart - home services. *Distributor Sensor Network*, 9-10.
- [10] Sonkar, B. S. (2015). Microcontroller-based LPG Leakage Detector using GSM Module. *International Journal of Electrical and Electronics Research, Vol .111*, 264-269.
- [11] Sperl, J. (2005). System pinpoints Leak s on point Arguello Offshore Lines. *Oil and Gas Journal. vol .99, no 36*, 47-55.
- [12] Yalmar, A. P. (2015). Implementation of automatic safety gas stove. *Ann IEEE India Conference* (pp. 1-6). New Delhi: INDICON.
- [13] Zhang, X. (2006). Statistical Leak Detection in Gas and Pipelines. *pipes and pipelines international ,vol 68 .no 4*, 20-30

Authors' Profiles



Nureni Asafe Yekini is a lecturer in the department of Computer Engineering Yaba College of Technology Lagos Nigeria. He obtained his academic qualification as follows: MSc. in Computer Science, University of Lagos Nigeria (UNILAG); BSc. in Electronic and Computer Engineering, Lagos State University (LASU), and NCE (National Certificate in Education) in Physics Lagos State College of Education Ijanikin (LACOED). He has written several textbooks in Computer Sciences and Engineering. He is a co-author and singular author of several academic publications that has features in some revered international journals and conference proceedings both in Nigeria and in abroad. He is currently an author with widely read and cited publication across the globe from YabaTech on researchgate.net. He is a Member of the following academic and professional bodies. Nigeria Computer Society (NCS), International Association of Engineers (IAENG) International Association of Computer Science and Information Technology (IACSIT); Member Institute of Electrical Electronic (MIEEE); COREN registered engineer, and Fellow IPMD



Oyeranmi Adigun (PhD) is the 8th Director, Centre for Information Technology and Management, Yaba College of Technology. Adigun holds a Bachelor of Science degree in Computer Science from the University of Ibadan, a Master degree in Business Administration from University of Ilorin, a Master's degree of Computer Science from University of Lagos, a Master of Philosophy from Universite de Nancy 2 Nancy, France, and a PhD in Computer Science from Ladoko Akintola University of Technology Ogbomoso, Oyo State, Nigeria. A widely travelled researcher, academic and administrator, he spent his early career life as Lecturer at Kwara State Polytechnic Ilorin, Kwara state. At Yaba College of Technology, Adigun was a two-term Head of Department (2004-2008); Dean of the School of Technology (2011-2014). Adigun is a CPN Registered member and member Nigeria Computer Society and other professional bodies. He has published more than 38 research papers in leading International peer-reviewed journals and conference proceedings.



Oloyede O. Adetokunbohas a National Diploma in Computer science from Federal Polytechnic Offa (1997); BSc Computer Engineering from Obafemi Awolowo University, Ile-Ife (2005) and just completed M.Engr (Information and Communication Engineering) from Covenant University Ota (2016). She is presently a lecturer in the department of Computer Engineering, Yaba College of Technology, Yaba, Lagos Nigeria; a prolific researcher; the secretary of her institution's faculty journal and has over 8 years of teaching experience in Polytechnic education having taught both national and higher national undergraduate students in various courses such as wired and wireless networks, computer architecture, assembly language, microprocessor and microcontroller to mention a few. She has published several papers in various international and national journals and conferences. She is a student fellow of IEEE and IEE.



Akinade Abigail Oluwatoyin, (Mrs) has Bachelor of Technology (computer science and engineering), Master of Science (Computer Science). She is currently and academic staff in the department of Computer Technology. Yaba College of Technology. Lagos Nigeria.

How to cite this paper: Yekini N. Asafe, Adigun J. Oyeranmi, Oloyede A. Olamide, Akinade O. Abigail, "Gas Leakage Detector and Monitoring System", International Journal of Engineering and Manufacturing (IJEM), Vol.12, No.5, pp. 56-65, 2022. DOI:10.5815/ijem.2022.05.05