

# Development of a New Diversity Scheme in 5G Network at 28 GHz Millimeter-wave Frequency for Digital Mobile System

Akinyinka Olukunle Akande<sup>a</sup>, Cosmas Kemisdrin Agubor<sup>a</sup>, Olusola Kunle Akinde<sup>b</sup>, Longinus Sunday Ezema<sup>a</sup>, Samuel Okechukwu Okozi<sup>a</sup>

<sup>a</sup>Federal University of Technology, Owerri, Nigeria

<sup>b</sup>The First Technical University, Ibadan, Oyo State, Nigeria

E-mail: akandeoluk@gmail.com

Received: 21 November 2020; Accepted: 10 January 2021; Published: 08 February 2021

**Abstract:** This paper presents an improved hybrid Equal Gain Combiner-Maximal Ratio Combiner (EGC-MRC) diversity scheme in 5G millimeter wave (mm-wave) frequency. The term 5G mm-wave refers to the radio frequency spectrum between 24 GHz and 100 GHz. The signal interference is a challenging task in 5G mm-wave frequency, and radio network suffer from co-channel and adjacent channel interference. 5G network deployment depends on large number of antennas, which resulted in signal interference. The conventional receiver's diversity techniques have high hardware complexity and are characterized by low performance. A new hybrid EGC-MRC diversity scheme was proposed as an improvement on the performance of existing MRC scheme. In achieving this, Probability Density Function (PDF) of the hybrid model was derived using the instantaneous Signal-to- Noise Ratio (SNR) obtained from the output of MRC and EGC diversity schemes. The performance of the developed model was evaluated using Outage Probability ( $P_{out}$ ) and Processing time ( $P_t$ ) at different SNR with  $L$  number of paths. Simulation of the MRC, EGC and hybrid EGC-MRC models were carried out using MATLAB 2018a and the results compared. The output results showed that hybrid EGC-MRC performed better than EGC and MRC by having a lower  $P_{out}$  and  $P_t$ . This new model has the potential to mitigate network interference, multipath propagation, and hardware complexity in 5G mm-wave frequency. Therefore, the developed model can be deployed by network operators to solve signal interference in 5G network.

**Index Terms:** 5G Network, Diversity Scheme, Hardware Complexity, Multipath fading, Millimeter-wave.

## 1. Introduction

Wireless communication system has experienced rapid growth recently due to lots of services available in mobile radio communication system [1]. Wireless communication systems suffer from multipath propagation effects such as signal attenuation, path loss, multipath propagation, Doppler and delay spread [2]. Fading occurs as a result of the interference between two or more mobile radio signals, which arrives at slightly different times at the receiver. The signal that is being transmitted travel through many paths due to the presence of reflectors and obstruction in the space which results in multipath signal propagation [3]. In this regard, fading compensation is needed to cushion the effect of signal attenuation.

### Nomenclature

16-QAM	16 Quadrature Amplitude Modulation
4-QAM	4 Quadrature Amplitude Modulation
5G	Fifth Generation
8-QAM	8 Quadrature Amplitude Modulation
BER	Bit Error Rate
BPSK	Binary Phase Shift Keying
CDF	Cumulative Density Function
EG	Equal Gain
EGC	Equal Gain Combiner
LOS	Line of Sight
MF	Matched Filter

MIMO	Multiple Input Multiple Output
MR	Maximal Ratio
MRC	Maximal Ratio Combiner
NLOS	Non-Line of Sight
$P_t$	Processing Time
PDF	Probability Density Function
$P_{out}$	Outage Probability
QAM	Quadrature Amplitude Modulation
QPSK (4-PSK)	Quadrature Phase Shift Keying
RF	Radio Frequency
SC	Selection Combining
SC-EG	Selection Equal Gain
SC-MR	Selection Maximal Ratio
SER	Symbol Error Rate
SIMO	Single Input Multiple Output
SNR	Signal-to-Noise Ratio
TC	Threshold Combining
TWDP	Two Wave With Diffuse Power

Diversity schemes are the method normally deployed at the receiver to combine multiple copies of the signal in the channel to obtain a single improved radio signal that enters the receiver [4]. The multiple signals from the channel are combined using diversity technique to obtain more reliable output signal [5]. The most popular and frequently used fading channel models in mobile communication systems are Rayleigh, Rician and Nakagami [6]. Rayleigh fading is mostly applicable where no line of sight (NLOS) exists. The Rayleigh fading distribution is mostly used to model the time varying nature of the received signal. The Rician distribution is observed where line of sight (LOS) exist between the transmitting antenna and the receiving antenna in the communication system [7].

The existing diversity combining scheme mostly used in signal prediction are Maximal Ratio (MR) Combining, Threshold Combining (TC), Selection Combining (SC), and Equal Gain (EG) Combining. The most commonly used hybrid techniques are Selection-Maximal Ratio (SC-MR) combining and Hybrid Selection-Equal Gain (SC-EG) combining [8]. It was reported that the MRC combiner performed better compared to other methods, but suffered hardware complexity. Signal reliability is very important in digital signal communication system. The use of multiple antenna is a good method to reduce the number of drop calls and loss connections [9].

However, additional hardware circuitry is needed with multiple filters in antenna diversity schemes [10]. This is a drawback on existing combining techniques. Multiple Input Multiple Output (MIMO) technology allows multiple users to share the same network resources simultaneously. Massive MIMO is one of the key enabling technology of 5G's network extremely fast data rates. This massive MIMO group antennas together at both transmitter and the receiver to provide high spectral and energy efficiency [11]. Beamforming is the ability of the base station to adapt the radiation pattern of the antenna. Beamforming helps the base station to find a suitable route to deliver data to the user, and it also reduces interference between nearby users [11].

The millimeter-waves cannot penetrate through obstacles and do not propagate to longer distances due to a shorter wavelength. Beamforming helps to send concentrated beams towards the users. Again, beamforming helps user to receive a strong signal without interference with other users in the channel [12]. The massive MIMO antenna interference becomes more challenging to manage in the dense environment. Hence, interference in fifth Generation (5G) mobile network is very crucial for millimeter-wave frequency bands due to the deployment of large number of antenna.

Millimeter-waves are frequency between 30 GHz to 300 GHz, and it is called millimeter-waves because its length varies from 1 to 10 mm. Millimeter-waves can provide bandwidth ten times more than that of the entire 4G cellular band. The mm-wave has small wavelength, and are not suitable for long distance propagation. The term 5G mm-wave refers to the radio frequency spectrum between 24 GHz and 100GHz, which have a very short wavelength. This mm-wave technology aims to increase the amount of bandwidth available, since low frequencies are congested with TV and radio signal, as well as 4G LTE network at 800 to 3000 MHz [13]. Millimeter-waves cannot penetrate buildings and obstacles, and they tend to get absorbed by rain. This is perhaps the most common issues cited with upcoming 5G networks. Most building materials, such as cement and brick, attenuate and reflect very high frequency signals with a big enough loss.

The high-frequency 5G mm-wave signals don't travel far in mobile communication channel, but it will bounce around them to ensure a decent signal [14]. However, massive MIMO and beamforming ensure that strict LOS is not a requirement to make use of millimeter-wave. 5G network mm-wave cannot penetrate thick object and foliage, which resulted in interference, power loss, and signal attenuation [15]. Hence, the signal bounce around object to reach its destination. The developed EGC-MRC model combines signal from many path and equalize them to obtain a robust signal power at the receiver.

In the 5G wireless network, mm-wave has a huge and potential frequency band available to fulfil the demand of high data rate, however, different challenges seem to make it more difficult. The mm-wave is one of the enabling technology that is being explored in 5G mobile network [11]. This mm-wave are easily absorbed by foliage and building, and will require many closely spaced transceiver stations to serve different network users. The deployment of large number of antennas in mm-wave bands causes interference, and multipath fading due to signal obstruction along its paths, which resulted to signal degradation [14].

The objective of this paper is to develop an appropriate model to solve signal interference and hardware complexity in 5G network. The Probability Density Function (PDF) of the hybrid model was derived using instantaneous Signal-to- Noise Ratio (SNR) obtained from the output of MRC and EGC diversity schemes. This model is different from existing models, for the fact that it will help to eliminate interference and hardware complexity in the course of implementing diversity combiner at the receiver. The outage probability and processing time were used to evaluate the accuracy of the new hybrid model. The Quadrature Phase Shift Keying (QPSK) and Quadrature Amplitude Modulation (QAM) scheme was deployed with Hybrid EGC-MRC combiner at the receiver with single Radio Frequency (RF) chain and filter to obtain quality and non-overlapping signal at the receiver. The online binary number was generated to carry out computer simulation using MATLAB 2018a software for different signal paths and modulation techniques. This is because the real 5G network data is not available at the time of carry out this research.

The new developed hybrid model with a significant improvement and good performance over the conventional models is an interesting contribution presented in this paper. Another contribution is the use of single filter and RF chain resulting in reduced hardware complexity unlike existing models. The hybrid model show better performance in 5G mm-wave frequency with reduced outage probability and lower processing time. Therefore, the developed model has the potential to mitigate signal interference, multipath fading, and power loss in 5G network. This ability to obtain improved hybrid model with better performance compared to existing models is the major contribution of this work. Organization of the paper starts with section 1, which is the introduction followed by literature review in section 2. Formulation of the system model, mathematical expression for new hybrid scheme, and simulation parameters are contained in sections 3, 4 and 5, respectively. The results are discussed in section 6, while section 7 is the conclusion.

## 2. Literature Review

Authors in [16] proposed a hybrid of SC- MRC scheme as new diversity technique over Two Wave with Diffuse Power (TWDP) in Rayleigh fading channel. The proposed model reported to be good, but with high hardware complexity and noise interference. In [2], the analysis of SC-MRC as hybrid diversity scheme over Nakagami communication fading channel was presented. The results show that when number of paths or users increases, the outage probability value also increase, which may be as a result of signal interference. The authors in [17] discussed the Performance evaluation of different diversity scheme in Rayleigh communication channel. It was found that MRC performed better than both SC and EGC diversity combiners.

Also, Authors in [2] proposed MRC-SC as a hybrid diversity method in Rayleigh fading environment. The results show that MRC-SC scheme provide a better performance compared to Selection Combining (SC), but suffers high hardware complexity. Author in [3] worked on the review of hybrid diversity techniques over various fading channels. It was reported that most of the existing models suffer signal interference and cannot solve the problem of multipath propagation in mobile radio channel.

In [7], the comparative analysis of different diversity scheme namely SC, MRC, EGC, and their performance over Rayleigh channel with BPSK modulation scheme was investigated. The results show that MRC gave better performance than SC and EGC diversity techniques, but with increase in Signal to Noise Ratio. A similar result of the performance MRC over EGC and SC was reported in [18]. The investigation of outage probability of dual receiver over Rician communication channel was also carried out in [19]. The results show that the outage probability of EGC and SC is higher compared to MRC combiner when the number of path increases.

The authors in [20] proposed a simple hybrid diversity scheme with Binary Phase Shift Keying (BPSK) modulation scheme for Single Input Multiple Output (SIMO) system in Rayleigh fading environment. The results show that at higher bit rate, when the transmitted bit increases, the model suffers from interference and high complexity, which may lead to increase in cost.

In [21], the comparative analysis of diversity schemes in SIMO multicast wireless network in the presence of diversity and without diversity combiner was reported. The results show that MRC diversity technique is good for multicast communication network system, but suffers high level of interference and hardware complexity.

The above mentioned network impairment prompts the necessity to develop a suitable model for signal transmission in 5G mm-wave frequency. The study proposed EGC-MRC as a new hybrid diversity scheme in Rayleigh fading environment. This scheme, which has not been proposed in previous reviewed works was evaluated using outage probability ( $P_{out}$ ) and signal processing time ( $P_t$ ). Therefore, with the deployment of the hybrid EGC-MRC scheme in 5G network at 28 GHz mm-Wave frequency, the proposed hybrid model has the capability to mitigate interference, signal loss, and multipath propagation.

### 3. System Model

The deployment of large number of antennas in 5G network for indoor and outdoor propagation within small distance always result in signal interference and multipath propagation in Raleigh fading channel. A new model was designed to mitigate these channel impairments. This hybrid model consists of three EGC combiners whose outputs are fed into the input of the MRC combiner. The random generated data was modulated using 4-PSK and 16-QAM. The base band signal is received by M number of antennas of the EGC diversity combiner branch. These M number of the signal from the branches of each EGC receiver with equal gains and acceptable signal level are combine to give improved signal values with equal weight. Then the signal from L number of EGC are fed into MRC to combine only the signals above the set threshold with maximum value of SNR. The resultant robust output from EGC-MRC hybrid diversity combiner is passed through single RF chain and single MF filter to the receiver. The proposed hybrid model is presented in Fig.1.

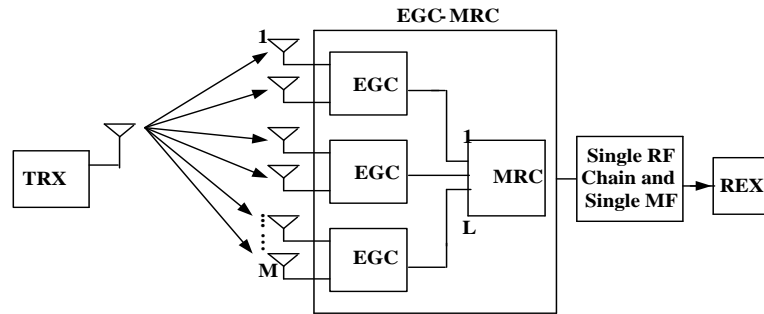

Fig. 1. The Proposed model for the hybrid MRC-EGC combiner

Considering the transmitted signal received by a receiver with M antennas and L EGCs scheme in a Rayleigh fading environment. The output instantaneous SNR of EGC combiner is given by [17] as:

$$\gamma_{EGC}(\gamma_t) = \frac{\gamma^{m-1} e^{-\gamma/\bar{\gamma}}}{\bar{\gamma} \Gamma(m)} \quad (1)$$

Where  $\gamma_{EGC}(\gamma_t)$  is the output instantaneous SNR of EGC,  $\bar{\gamma}$  is the average SNR of received signal,  $\gamma$  is the SNR of received signal of the EGC,  $\Gamma(m)$  is the gamma function, and  $m$  is the number of signal paths.

#### 3.1. Mathematical Analysis of PDF and $P_{out}$ for EGC

The close form expression was obtained in terms of probability density function and outage probability for EGC combiner.

##### 3.1.1. Probability Density Function of EGC

The Probability Density (PD) function of the output SNR of the EGC diversity combiner is given by [22] as;

$$PDF_{EGC}(\gamma_t) = \frac{1}{\bar{\gamma}_{av}} e^{-\frac{\gamma_t}{\bar{\gamma}_{av}}} + \sqrt{\pi} e^{-\frac{\gamma_t}{\bar{\gamma}_{av}}} * [l(\gamma_t, \bar{\gamma}_{av})] \quad (2)$$

where,

$$[l(\gamma_t, \bar{\gamma}_{av})] = \left( \frac{1}{2(\bar{\gamma}_{av}\gamma_t)^{\frac{1}{2}}} - \frac{1}{\bar{\gamma}_{av}} \left( \frac{\gamma_t}{\bar{\gamma}_{av}} \right)^{\frac{1}{2}} \right), \quad (3)$$

$\bar{\gamma}_{av}$  is the average SNR of the EGC combiner and  $\gamma_t$  is the instantaneous SNR of the output of the EGC. Substituting equation (1) into equation (2) gives;

$$PDF_{EGC}(\gamma_t) = \frac{1}{\bar{\gamma}_{av}} e^{-\frac{\gamma_t}{\bar{\gamma}_{av}}} + D(m\gamma) * A(\gamma, \Gamma m] \quad (4)$$

where,

$$[D(m\gamma)] = \sqrt{\pi} e^{-\frac{\gamma^{m-1} e^{-\gamma/\bar{\gamma}}}{\bar{\gamma}\Gamma(m)}} \frac{1}{\bar{\gamma}_{av}} \quad (5)$$

$$A(\gamma, \Gamma m) = \left( \frac{1}{2 \left( \frac{\gamma^{m-1} e^{-\gamma/\bar{\gamma}}}{\bar{\gamma}\Gamma(m)} \right)^{\frac{1}{2}}} - \frac{1}{\bar{\gamma}_{av}} \left( \frac{\gamma^{m-1} e^{-\gamma/\bar{\gamma}}}{\bar{\gamma}\Gamma(m)} \right)^{\frac{1}{2}} \right) \quad (6)$$

### 3.1.2. Outage Probability of EGC

The Outage Probability ( $P_{out}$ ) for EGC is given as the integral of the equation (4) by [22, 23] as;

$$P_{out} = \int_0^{\gamma_o} PDF_{EGC}(\gamma_t) d\gamma \quad (7)$$

Substituting equation (4) into (7) results to;

$$P_{out(EGC)} = \int_0^{\gamma_o} \frac{1}{\bar{\gamma}_{av}} e^{-2 \frac{\gamma^{m-1} e^{-\gamma/\bar{\gamma}}}{\bar{\gamma}\Gamma(m)}} + [D(m\gamma) * A(uk)] d\gamma \quad (8)$$

where,  $\gamma_o$  is the set threshold value, and  $\gamma$  is the SNR of received signal of the EGC

### 3.2. Mathematical Analysis of PDF and $P_{out}$ for MRC

The close form expression was obtained in terms of probability density function and outage probability for EGC combiner.

#### 3.2.1. Probability Density Function of MRC

The transmitted signal received by L-branch MRC scheme instantaneous SNR at the output of the diversity combiner is given by [17];

$$\gamma_{mrc} = \frac{\gamma^{l-1} \exp^{-\gamma/\bar{\gamma}}}{\bar{\gamma}^{l-1} (l-1)} \quad (9)$$

where  $\gamma_{mrc}$  is the output instantaneous SNR of the MRC,  $l$  is the number of branches, and  $\bar{\gamma}$  is the average SNR of the received signal (MRC). The Probability Density Function of MRC ( $PDF_{MRC}$ ) is given by [24, 25];

$$PDF_{MRC} = \frac{\gamma_{mrc}^{l-1}}{(l-1)! \bar{\gamma}_{av}^l} \exp\left(-\frac{\gamma_{mrc}}{\bar{\gamma}_{av}}\right) \quad (10)$$

Substituting equation (8) into equation (10) results to;

$$PDF_{MRC}(\gamma_t) = \frac{\left( \frac{\gamma^{l-1} \exp^{-\gamma/\bar{\gamma}}}{\bar{\gamma}^{l-1} (l-1)} \right)^{l-1}}{(l-1)! \bar{\gamma}_{av}^l} \exp\left(-\frac{\gamma^{l-1} \exp^{-\gamma/\bar{\gamma}}}{\bar{\gamma}^{l-1} (l-1)} \frac{1}{\bar{\gamma}_{av}}\right) \quad (11)$$

where,  $\gamma$  is the SNR of received signal of the MRC and  $\bar{\gamma}_{av}$  the average SNR of the combiner.

#### 3.2.2. Outage Probability of MRC

The integral of the Outage Probability  $P_{out}$  for MRC is given as;

$$P_{out} = \int_0^{\gamma_o} PDF_{MRC}(\gamma_t) d\gamma \quad (12)$$

Substituting equation (11) into equation (12) produces outage probability of MRC;

$$P_{out(MRC)} = \int_0^{\gamma_0} \frac{\left(\frac{\gamma^{l-1} \exp^{-\gamma/\bar{\gamma}}}{\bar{\gamma}^{l-1}}\right)^{l-1}}{(l-1)! \bar{\gamma}_{av}^l} \exp\left(-\frac{\gamma^{l-1} \exp^{-\gamma/\bar{\gamma}}}{\bar{\gamma}_{av}}\right) d\gamma \quad (13)$$

where,  $\gamma_0$  is the set threshold and  $\gamma$  the SNR of received signal.

#### 4. The Mathematical Expressions for New Hybrid Scheme

The mathematical expressions for the new hybrid EGC-MRC was achieved using the Probability Density Function (PDF) of EGC and MRC diversity combiner. Thus, the PDF of the new Hybrid model is presented in equation (14) as:

$$PDF_{EGC/MRC}(\gamma_t) = PDF_{EGC}(\gamma_t) * PDF_{MRC}(\gamma_t) \quad (14)$$

With the substitution of equations (3) and (8) into equation (11) to produced new hybrid model given in equation (15). This new hybrid model was developed from existing EGC and MRC models. The performance of the developed model was evaluated using outage probability and signal processing time. The model is very unique with better, and more accurate result compared to the existing models.

$$PDF_{MRC-EGC}(\gamma_t) = \frac{1}{\bar{\gamma}_{av}} e^{-2\frac{\gamma^{m-1} e^{-\gamma/\bar{\gamma}}}{\bar{\gamma} \Gamma(m)}} + [D(m\gamma) * A(\gamma, \Gamma m)] * [B(k, \gamma l)] \quad (15)$$

where:

$$B(k, \gamma l) = \frac{\left(\frac{\gamma^{l-1} \exp^{-\gamma/\bar{\gamma}}}{\bar{\gamma}^{l-1}}\right)^{l-1}}{(l-1)! \bar{\gamma}_{av}^l} \exp\left(-\frac{\gamma^{l-1} \exp^{-\gamma/\bar{\gamma}}}{\bar{\gamma}_{av}}\right) \quad (16)$$

$\gamma_{EGC}(\gamma_t)$  is the instantaneous SNR output of the EGC, and  $\gamma_{MRC}(\gamma_t)$  is the instantaneous SNR output of the MRC

##### 4.1. Performance Metrics for MRC-EGC Receiver

The Outage Probability ( $P_{out}$ ) and Signal Processing Time ( $P_t$ ) are the metrics used to evaluate the performance of the proposed hybrid model in fading environment.

##### 4.1.1. Outage Probability

This is the probability that output  $P_\gamma(\gamma)$  of the SNR will fall below a threshold value ( $\gamma_0$ ) is given by [17, 18];

$$P_{out} = \int_0^{\gamma_0} P_\gamma(\gamma) d\gamma \quad (17)$$

Substituting equation (8) and equation (13) into equation (17), the outage probability of the new hybrid model is presented in equation (18) as:

$$P_{out(MRC-EGC)} = \int_0^{\gamma_0} PDF_{EGC}(\gamma_t) * PDF_{MRC}(\gamma_t) d\gamma \quad (18)$$

where,  $\gamma_0$  is the set threshold value,  $PDF_{EGC}(\gamma_t)$  is the PDF of EGC scheme and  $PDF_{MRC}(\gamma_t)$  is the PDF of MRC scheme.

##### 4.1.2. Processing Time

Processing time is the time taken (in seconds) to complete simulation process when the signal propagates from source to the receiver. Signal processing time depends on the number of the hardware devices employed in the system design.

#### 5. Simulation Parameters

The simulation of the MRC, EGC and hybrid EGC-MRC models were carried out using MATLAB R2018a software tool. It provides an interactive environment and low cost compared with the field test measurements. The

simulation was carried out using randomly generated binary data format using 4-PSK and 16-QAM as modulation schemes in 5G network at 28 GHz mm-wave frequency. The network simulation parameters are given in Table 1.

Table 1. Network Simulation Parameters

Parameters	Variables
Modulation	BPSK (2-PSK), 4-PSK, 8-PSK, 16-QAM
Channel	Rayleigh
No of paths (L)	2,3
Carrier Frequency	28000 MHz
Noise	AWGN
LOS Component (k)	3
SNR	2 dB - 10 dB
Data length	10,000
(Set threshold) $Y_0$	2dB
Base Station power	1watts

### 6. Results and Discussion

Hybrid EGC-MRC diversity scheme has been developed and simulated using the appropriate 5G network parameters. The conventional EGC and MRC schemes were analytically combined to produce new hybrid EGC-MRC diversity combiner. The Rayleigh fading channel was adopted since there are many obstructions such as trees, building, foliage that scatter the radio signal in the communication channel and create multipath fading. The Outage Probability ( $P_{out}$ ) and Processing time ( $P_t$ ) results were obtained for EGC, MRC and Hybrid EGC-MRC at different level of SNR and 28000 MHz frequency band.

Fig. 2 shows the comparative plot of  $P_{out}$  against different values of SNR. At  $L = 2$  and 4PSK (QPSK) modulation scheme, the  $P_{out}$  values for EGC were 0.62 dB, 0.35 dB, 0.28 dB, 0.23 dB, and 0.20 dB at SNR of 2, 4, 6, 8, and 10, respectively, while the corresponding values of  $P_{out}$  for MRC were 0.35 dB, 0.19 dB, 0.14 dB, 0.12 dB, and 0.10 dB. The Hybrid EGC-MRC shows a better performance compared to EGC and MRC with  $P_{out}$  values of 0.22 dB, 0.07 dB, 0.04 dB, 0.03 dB, and 0.02 dB at different SNR. The  $P_{out}$  values of hybrid model reduces with increase in SNR, this means that better signal reached the system destination without any interference.

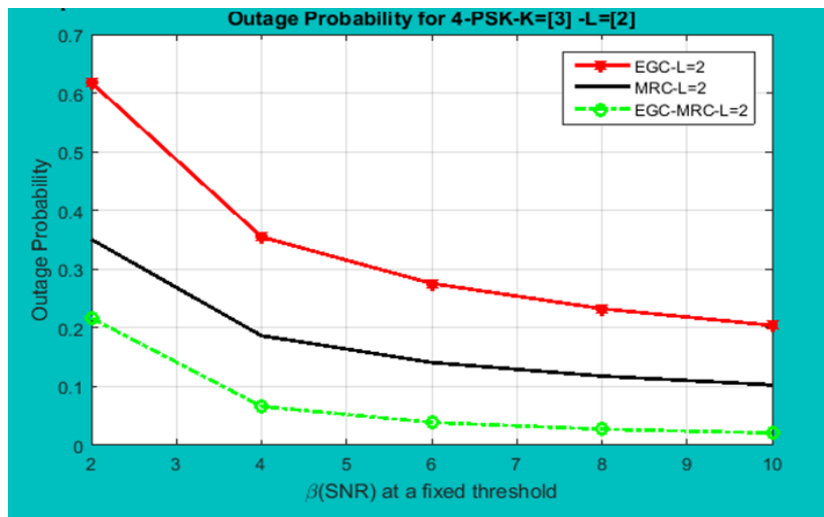

Fig. 2. Outage Probability against SNR for EGC, MRC and EGC-MRC L=2 and 4-PSK Modulation Scheme

Fig. 3 shows plot of  $P_{out}$  against different values of SNR. At  $L = 3$  and 4-PSK modulation scheme, the  $P_{out}$  values for EGC were 0.62 dB, 0.19 dB, 0.11 dB, 0.07 dB, and 0.05 dB at SNR of 2, 4, 6, 8, and 10, respectively, while  $P_{out}$  corresponding values of MRC were 0.31 dB, 0.10 dB, 0.05 dB, 0.04 dB, and 0.03 dB. The Hybrid EGC-MRC is observed to have a better performance compared to EGC and MRC with  $P_{out}$  values of 0.19 dB, 0.02 dB, 0.01 dB, 0.001 dB, and 0.001 dB at SNR of 2, 4, 6, 8, and 10, respectively

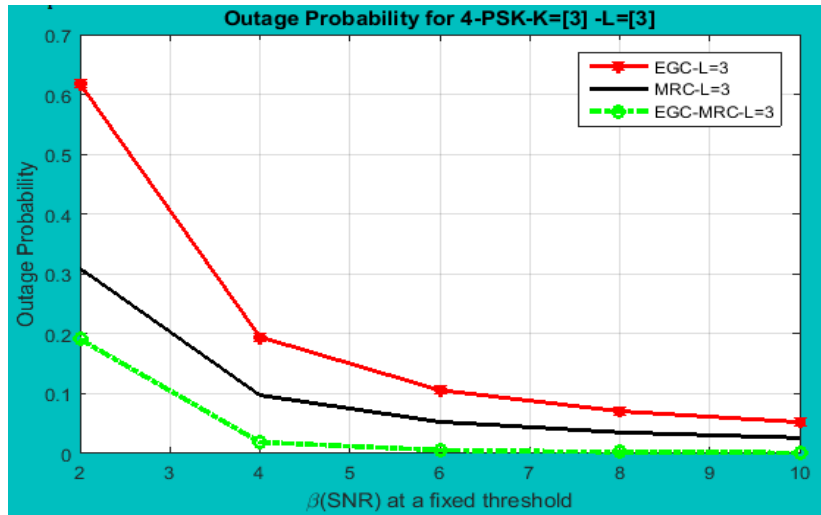

Fig. 3. Outage Probability against SNR for EGC, MRC and EGC-MRC at L=2 and 4-PSK Modulation Scheme

Fig. 4 depicts the plot of processing time plotted in bar chart against SNR at a fixed threshold. . At  $L = 2$  and 4- $QAM$  modulation scheme, the  $P_t$  values for EGC were 0.96 sec, 0.96 sec, 0.96 sec, 0.96 sec, and 0.96 sec at SNR of 2, 4, 6, 8, and 10 respectively, while the values of  $P_t$  for MRC were 0.90 sec, 0.96 sec, 0.90 sec, 0.96 sec, and 0.96 sec. The Hybrid EGC-MRC performance better than EGC and MRC with  $P_t$  values 0.76 sec, 0.76 sec, 0.76 sec, 0.76 sec, and 0.76 sec at different SNR. It can be observed that hybrid model gave lower processing time compare to conventional diversity models, which means the new model has the potential to mitigate the hardware complexity in the communication network.

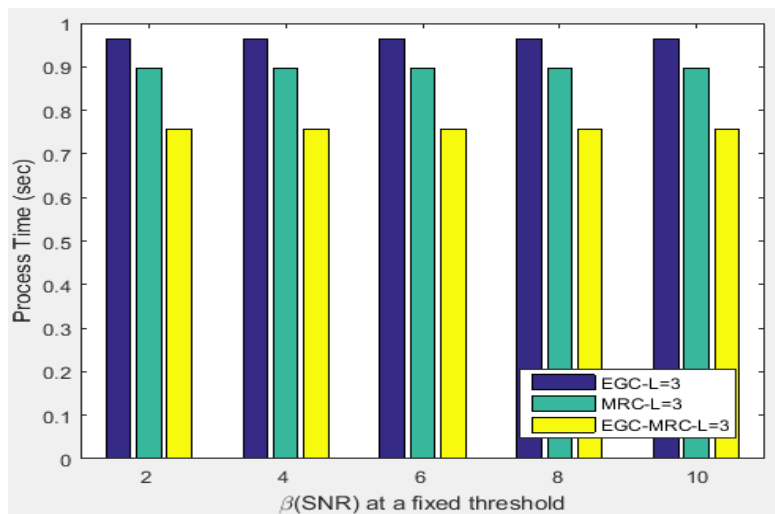

Fig. 4. Processing Time against SNR for EGC, MRC and EGC-MRC at L=3 and 4-PSK Modulation Scheme

Fig. 5 presents the plot of Outage Probably values against different SNR. At  $L = 2$  and 8- $QAM$  modulation scheme, the values of  $P_{out}$  for EGC were 0.35 dB, 0.18 dB, 0.13 dB, 0.10 dB, and 0.08 dB at SNR of 2, 4, 6, 8, and 10 respectively, while the values of  $P_{out}$  for MRC were 0.22 dB, 0.10 dB, 0.07 dB, 0.05 dB, and 0.04 dB. The Hybrid EGC-MRC show a better performance compared to EGC and MRC with  $P_{out}$  values of 0.07 dB, 0.02 dB, 0.01 dB, 0.01 dB, and 0.01 dB at different SNR. It is observed that there was no signal interference in the channel and hybrid EGC-MRC shows a better performance compared to EGC and MRC.



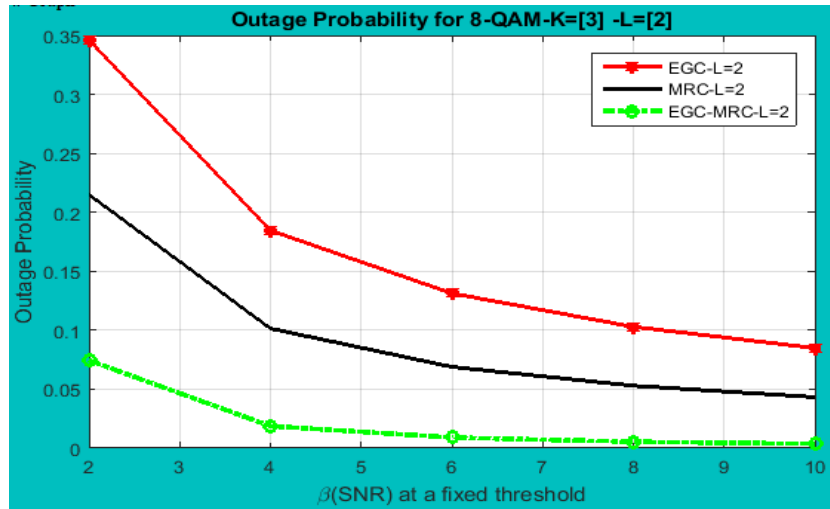

Fig. 5. Plot of Outage Probability against SNR for EGC, MRC and EGC-MRC at L=2 and 8-QAM Modulation Scheme

Fig. 6 presents the plot of  $P_{out}$  against different values of SNR. At  $L = 3$  and 8-QAM modulation scheme, the  $P_{out}$  values for EGC were 0.35 dB, 0.14 dB, 0.08 dB, 0.06 dB, and 0.04 dB at SNR of 2, 4, 6, 8, and 10, respectively, while the corresponding values of  $P_{out}$  for MRC were 0.17 dB, 0.07 dB, 0.04 dB, 0.03 dB, and 0.02 dB. The hybrid EGC-MRC gave a better performance with  $P_{out}$  values of 0.06 dB, 0.009 dB, 0.003 dB, 0.002 dB, and 0.001 dB at different SNR. Again, it was observed that probability of outage reduced with increase in SNR without signal interference.

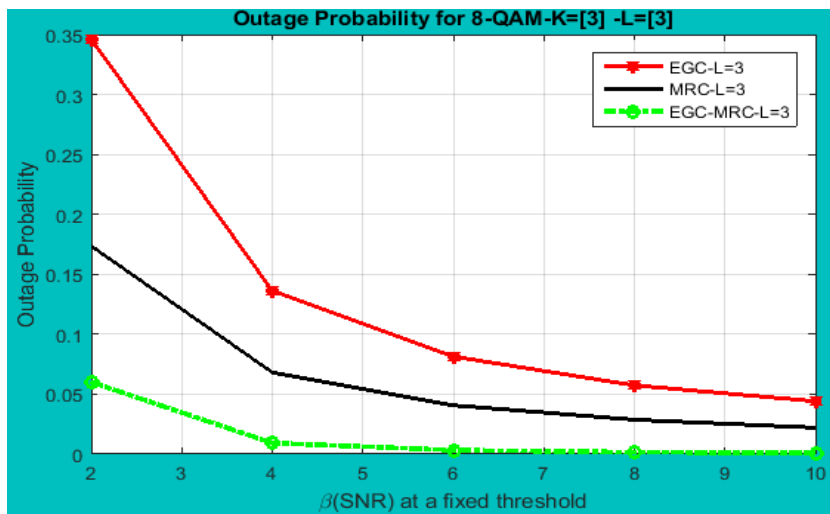

Fig. 6. Plot of Outage Probability against SNR for EGC, MRC and EGC-MRC at L=3 and 8-QAM Modulation Scheme

Fig. 7 depicts  $P_t$  plotted in bar chart against SNR at a fixed threshold. At  $L = 3$  and 8-QAM modulation scheme, the  $P_t$  values for EGC were 0.86 sec, 0.86 sec, 0.86 sec, 0.86 sec, and 0.86 sec at SNR of 2, 4, 6, 8, and 10, respectively, while  $P_t$  values for MRC were 0.63 sec, 0.63 sec, 0.63 sec, 0.63 sec, and 0.63 sec. The hybrid EGC-MRC gave a better performance compared to EGC and MRC with  $P_t$  values of 0.52 sec, 0.52 sec, 0.52 sec, 0.52 sec, and 0.52 sec at different SNR. The result shows that hybrid model produce lower processing time compared to existing diversity models. Hence, hybrid model can be deployed to mitigate the effect of hardware complexity in the system.

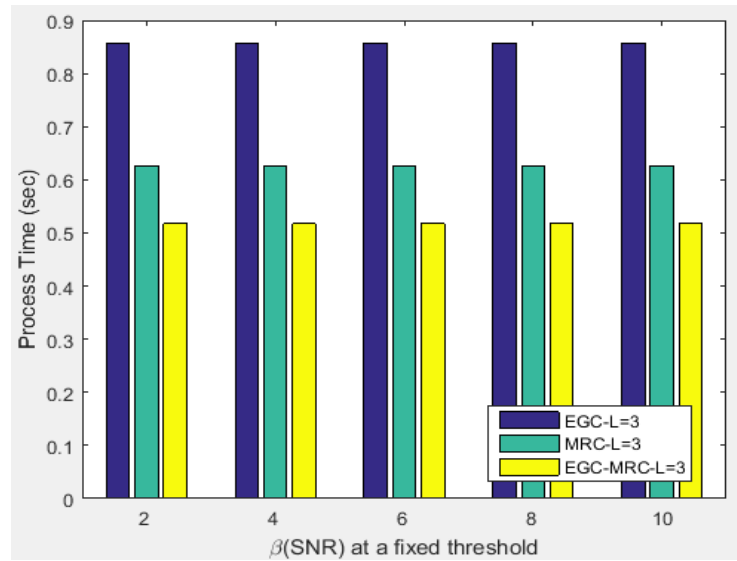

Fig. 7. Plot of Processing Time against SNR for EGC, MRC and EGC-MRC at L=3 and 8-QAM Modulation Scheme

Fig. 8 presents the plot of Outage Probable values against different SNR. At  $L = 2$  and 16-QAM modulation scheme, the  $P_{out}$  values for EGC were 0.35 dB, 0.18 dB, 0.13 dB, 0.10 dB, and 0.08 dB at SNR of 2, 4, 6, 8, and 10, respectively, while the values of  $P_{out}$  for MRC were 0.21 dB, 0.10 dB, 0.07 dB, 0.05 dB, and 0.04 dB. The hybrid EGC-MRC  $P_{out}$  values were 0.07 dB, 0.02 dB, 0.009 dB, 0.005 dB, and 0.004 dB at SNR of 2, 4, 6, 8, and 10, respectively.. It was observed that the Hybrid EGC-MRC shows a better performance compared to EGC and MRC.

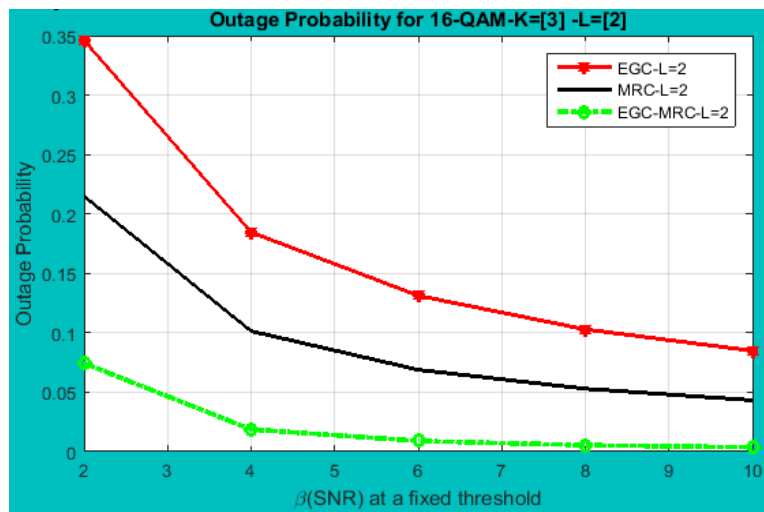

Fig. 8. Plot of Outage Probability against SNR for EGC, MRC and EGC-MRC at L=2 and 16-QAM Modulation Scheme

Fig. 9 depicts the plot of processing time plotted in bar chart against SNR at a fixed threshold. At  $L = 3$  and 16-QAM modulation scheme, the  $P_{out}$  values for EGC were 0.35 dB, 0.14 dB, 0.08 dB, 0.06 dB, and 0.04 dB at SNR of 2, 4, 6, 8, and 10, respectively, while the values of  $P_{out}$  for MRC were 0.17 dB, 0.07 dB, 0.04 dB, 0.03 dB, and 0.02 dB. The hybrid EGC-MRC  $P_{out}$  values were 0.06 dB, 0.009 dB, 0.003 dB, 0.002 dB, and 0.001 dB at SNR of 2, 4, 6, 8, and 10, respectively. The Hybrid EGC-MRC shows a better performance compared to EGC and MRC. It can be observed that hybrid model gave reduced outage probability and processing time with increase in SNR compared to EGC and MRC combiner. Hence, the hybrid EGC-MRC model can be deployed to cushion the effect of multipath propagation in the system.

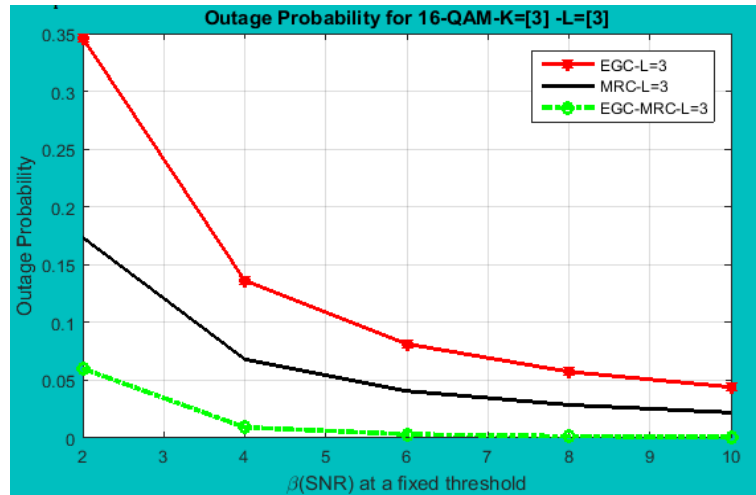

Fig. 9. Outage Probability against SNR for EGC, MRC and EGC-MRC at L=2 and 16-QAM Modulation Scheme

Fig. 10 depicts the plot of processing time plotted in bar chart against SNR at a fixed threshold. At  $L = 3$  and 16-QAM modulation scheme, the values of  $P_t$  for EGC were 0.99 sec, 0.99 sec, 0.99 sec, 0.99 sec, and 0.99 sec at SNR of 2, 4, 6, 8, and 10, respectively, while the corresponding values of  $P_t$  for MRC were 0.90 sec, 0.90 sec, 0.90 sec, 0.90 sec, and 0.90 sec. The hybrid EGC-MRC gave better result compared to EGC and MRC with  $P_t$  values of 0.72 sec, 0.72 sec, 0.72 sec, 0.72 sec, and 0.72 sec at different SNR. The result showed that hybrid model gave lower processing time, which can be deployed to solve the problem of hardware complexity in the system.

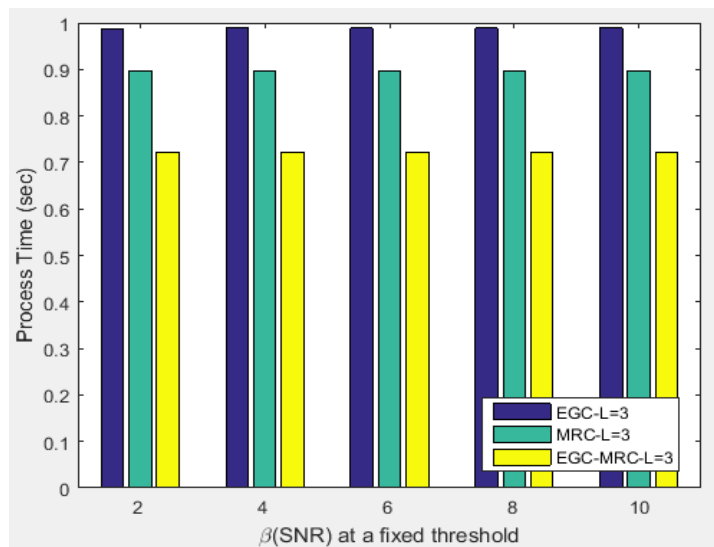

Fig. 10. Processing Time against SNR for EGC, MRC and EGC-MRC at L=3 and 16-QAM Modulation Scheme

Fig. 11 presents the comparative plot of the total  $P_{out}$  values against SNR. At  $L = 2, 3$  and 8-QAM, the  $P_{out}$  values for EGC is realized as 0.87 dB at  $L = 2$  and 0.69 dB at  $L = 3$ , while the corresponding values of  $P_{out}$  for MRC as 0.50 dB and 0.35 dB, respectively. Again, the result of  $P_{out}$  for hybrid EGC-MRC are obtained as 0.13 dB and 0.09 dB at  $L = 2$  and  $L = 3$ , respectively.

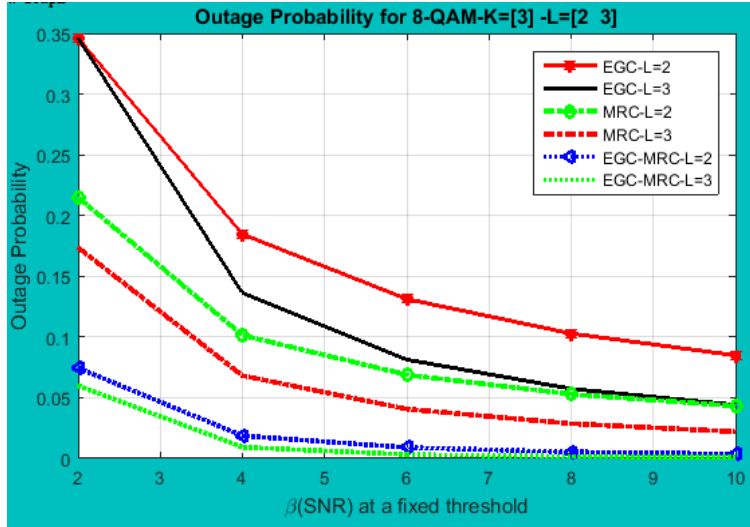

Fig. 11. Outage Probability versus SNR for EGC, MRC and hybrid EGC-MRC at L= 2, 3 and 8-QAM Modulation Scheme

Fig. 12 depicts the comparative plot of the total  $P_t$  values against different SNR. At  $L = 2, 3$  and 8-QAM, the  $P_t$  values for EGC is obtained as 4.47 sec at  $L = 2$  and 4.47 sec at  $L = 3$ , while the corresponding values of  $P_t$  for MRC as 3.99 sec and 3.99 sec, respectively. Again, the result of  $P_t$  for hybrid EGC-MRC are realized as 2.73 sec and 2.73 sec at  $L = 2$  and  $L = 3$ , respectively.

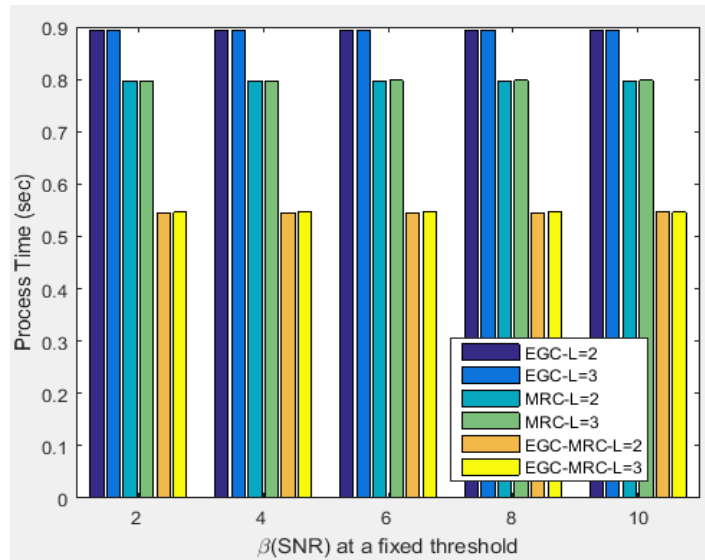

Fig. 12. Outage Probability versus SNR for EGC, MRC and hybrid EGC-MRC at L= 2, 3 and 8-QAM Modulation Scheme

Fig. 13 shows the comparative plot of the output probability values against SNR. At  $L = 2, 3$ ; and 16-QAM modulation scheme, the total  $P_{out}$  values realized for EGC at  $L = 2$  and  $L = 3$  were 0.87 dB and 0.69 dB respectively, while the corresponding values of  $P_{out}$  for MRC at  $L = 2$  and  $L = 3$  were 0.50 dB and 0.35 dB. The hybrid EGC-MRC  $P_{out}$  values obtained were 0.13 dB and 0.09 dB, respectively.

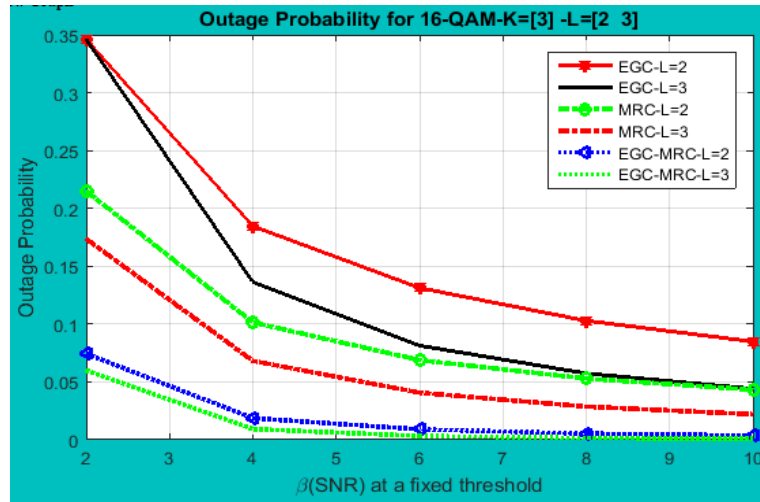

Fig. 13: Outage Probability against SNR for EGC, MRC and hybrid EGC-MRC at L= 2, 3 and 16-QAM Modulation Scheme

Fig. 14 depicts the comparative plot of the total  $P_t$  values against different SNR. The  $P_t(sec)$  values for EGC when  $L = 2$  and  $L = 3$  were gotten as 4.98 sec and 4.98 sec respectively, while the corresponding values of  $P_t(sec)$  for MRC when  $L = 2$  and  $L = 3$  are obtained as 4.52 sec and 4.52 sec. The hybrid system for the  $P_t(sec)$  values were realized as 3.76 sec and 3.76 sec, respectively.

The hybrid model demonstrated better performance with reduced  $P_{out}$  and  $P_t$  relative to the increase in the number of paths and SNR. The study clearly proved that the hybrid model is suitable to mitigate the problems associated with interference, and multipath propagation in 5G network owing to its reduced signal outage probability and processing time.

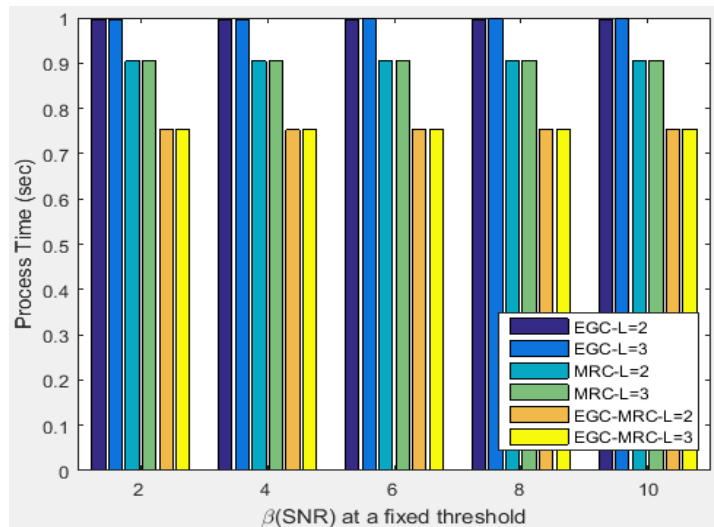

Fig. 14. Processing Time versus SNR for EGC, MRC and hybrid EGC-MRC at L= 2, 3 and 16-QAM Modulation Scheme

Fig. 15 presents plot of the output probability values against SNR. At  $L = 2, 3$ ; and  $BPSK (2-PSK)$  modulation scheme, the total  $P_{out}$  values realized for EGC at  $L = 2$  and  $L = 3$  were 3.36 dB and 1.79 dB respectively, while the corresponding values of  $P_{out}$  for MRC at  $L = 2$  and  $L = 3$  were 1.73 dB and 0.90 dB. The hybrid EGC-MRC  $P_{out}$  values obtained were 1.35 dB and 0.74 dB, respectively.

In this case,  $QPSK, 8-QAM,$  and  $16-QAM$  gave reduced outage probability values compared to  $BPSK$  modulation scheme. Again, the signal interference is observe in the result presented in Figure 15 with  $BPSK$  modulation scheme. The developed model cushion the effect of signal interference and multipath propagation in 5G mobile network with the deployment of  $QPSK, 8-QAM,$  and  $16-QAM$  modulation schemes. The results shows that  $BPSK$  cannot be handle the effect of interference at millimeter wave frequency, while other modulation scheme, such as  $QPSK, 8-QAM,$  and  $16-QAM$  have successfully mitigate signal interference and multipath propagation in 5G millimeter wave frequency.

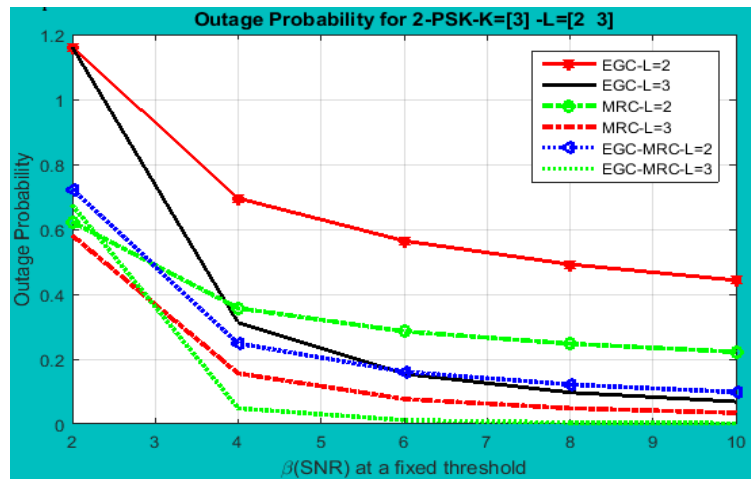

Fig. 15. Processing Time versus SNR for EGC, MRC and hybrid EGC-MRC at L= 2, 3 and BPSK (2-PSK) Modulation Scheme

## 7. Conclusion

In this research, a new hybrid EGC-MRC diversity combining model has been successfully developed and simulated using appropriate 5G network parameters in mm-wave frequency. The developed model was obtained by the combination of EGC and MRC as hybrid diversity combiner. The output of EGC combiner was applied as the input signal to MRC receiver, which was fed into single RF chain and matched filter. Mathematical equation for Probability Density (PD) function of the output signal was obtained for hybrid model, and this was used to derive Outage Probability  $P_{out}$  expression for the developed model. The  $P_{out}$  expressions for EGC, MRC, and hybrid EGC-MRC were obtained using output instantaneous SNR. The simulation was carried out using MATLAB 2018a software for different signal paths and modulation techniques. The Outage Probability ( $P_{out}$ ) values were plotted against the Processing time ( $P_t$ ) at different SNR between 2 dB to 10 dB. The results obtained showed that the hybrid EGC-MRC performed better than EGC and MRC by having a lower  $P_{out}$  and  $P_t$  with increase in SNR. It should be noted that 8-QAM and 16-QAM modulation scheme shows better result in terms of  $P_{out}$  and  $P_t$  compared to BPSK and 4-PSK modulation scheme. The model is very unique one that combined the features of two diversity schemes in Rayleigh environment with better, and more accurate result compared to the existing models. The developed model is applicable in mobile communication network. For the fact that existing model suffers hardware complexity and multipath propagation. The hybrid EGC-MRC gave reduced  $P_t$  due to reduction in number of filters and overall reduction in complexity. This reduction in hardware complexity is an added advantage in terms of system implementation cost. The 5G network deployment depends on large number of antennas, which resulted in signal interference. This new model is capable of mitigating network interference, signal loss, multipath propagation, and hardware complexity in 5G mm-wave frequency. Therefore, the developed model can be deployed by network operators to solve signal interference and multipath propagation in 5G network.

## References

- [1] Akande, A. O., Semire, F. A., and Adeyemo, Z. K. Performance Evaluation of the Optimized COST-231-Hata Model for Mobile Radio Communication System in Nigeria, *Inter. Journal of Computer Applications*, 2017; 173(6): 4-9.
- [2] Dinamani, A., Bijendra, L., Babina, S., Kiran, B., and Shruti, R. Analysis of a Hybrid MRC-SC Diversity Receiver in Rayleigh Communication Channel, Circuits, Controls and Communications (CCUBE), *IEEE 2013 International Conference*, India, 2013; 1-4
- [3] Singla, M., and Tiwana, S. A Review on Hybrid Diversity Techniques Over Various Fading Channels, *Inter., Journal of Engr., Tech., Management and Applied Sciences*, 2017; 5(4): 118-120.
- [4] Zhu, B., Wu, L., Cheng, J., and Yang, F. Performance of Diversity Reception over Arbitrarily Correlated Nakagami Communication Channels, *IEEE, Transaction Wireless Communication*, 2016; 15(1): 699 -713.
- [5] Nivethika, S., Sreeja, B., Manikandan, E., and Radha, S. Smart and Highly Efficient Mobile Radio Antenna with Low Cost Substrate, *Microwave and Optical Tech., Letters*, 2018; 60(7): 1798-1803.
- [6] Kanthimathi, M., Anusha, S., and Amutha, R. Modulation Analysis for Differential Amplitude and Phase Shift Keying Modulation Technique, *The Inter., J., of Engineering Tech*, 2018; 7(1): 418-420.
- [7] Walia, W., and Mahindru, A. Performance Evaluation of Conventional Diversity Combiner Techniques over Rayleigh and Rician Communication Channels, *Journal of Computer Engineering (IOSR-JCE)*, 2014; 16(3): 28-32.
- [8] Hoyong, L., Song, Y., and Sang, P. Performance Evaluation of a Hybrid SC-MRC Diversity Technique in Rayleigh Communication Channel, *Proceeding of 13th Inter. Conference on Advanced Communication Tech. (ICACT)*, Korea, 2011; 1115-1119.

- [9] Selvam, Y., Alsath, M., Elumalai, L., Malathi, K., and Kulandhaisamy, I. A Patch-Slot Antenna Array System with Compound Reconfiguration, *IEEE, Antenna and Wireless Propagation Letters*, 2018; 17(3): 525-528.
- [10] Subramanian, M., Joshitha, C., Sreeja, B., and Nair, P. Multiport RF MEMS Switch for Satellite Payload Applications, *Micro-system Technologies, Springer*, 2018; 24(5): 2379-2387.
- [11] Robin, C., and Robert A. Massive MIMO Systems for 5G and Beyond Networks-Overview, Recent Trends, Challenges, and Future Research Direction, *Journal Sensors, doi:10.3390/s20102753*, 2020; 1-35.
- [12] Molisch, A., Ratnam, V., Han, S., Li, Z., and Haneda, K. Hybrid Beamforming for Massive MIMO: A Survey. *IEEE Communications Magazine* 2017; 55: 134-141
- [13] Kutty, S., and Sen, D., Beamforming for Millimeter Wave Communications: An Inclusive Survey. *IEEE Communication Survey Tutorial*, 2016; 18(2): 49-973
- [14] Yang, B., Yu, Z., Zhou, J., and Hong, W. Digital Beamforming-Based Massive MIMO Transceiver for 5G Millimeter Wave Communications. *IEEE Transactions on Microwave Theory and Technology*, 2018; 66: 3403-3418.
- [15] Ali, E., Ismail, M., Nordin, R., and Abdulah, N. Beamforming Techniques for Massive MIMO Systems in 5G: Overview, Classification, and Trends For Future Research, *Frontiers of Information Technology & Electronic Engineering*, 2017; 18(6): 753-772.
- [16] Sodhi, R., and Khanna, R. Performance Evaluation of Hybrid Diversity Combining Schemes in TWDP Fading Communication Channel, *Indian Journal of Science and Tech.*, 2016; 9(4): 1-6
- [17] Nitika, S., and Deepak, S. Evaluation of Conventional Diversity Combining Techniques over Rayleigh Communication Channel, *Inter. Journal of Advanced Research in Computer Science and Software Engr*, 2012; 2(6): 197-201.
- [18] Agubor, C., Nosiri, O., Ononiwu, G., Atimati, E., and Onyishi, D. Techniques in Performance of Mobile Wireless Communication System: A Review, *European Journal of Engineering and Technology*, 2015; 3(3): 88-100.
- [19] Pathak, S., and Katiyar, H. Outage Performance of the Diversity Receiver in Rician Communication Channel, *Inter. Journal of Advanced Research in Science and Engineering*, 2016; 5(4): 685-697.
- [20] Sharma, P., and Buttar, A. Bit Error Rate Improvement over Rayleigh SIMO Channel Using Hybrid Diversity Combiner Method, *Inter., Journal on Recent and Innovation Trends in Computing and Comm.*, 2014; 2(8): 2355-2358.
- [21] Sayed, R., Shobug, M., and Badrudduza, A. Performance Evaluation of Diversity Combiner Scheme in Rician Fading and SIMO Multicasting Wireless Network, *Scholars Journal of Engineering and Tech. (SJET)*, 2016; 4(10): 489-499.
- [22] Goldsmith, A. *Wireless Communication System*. 2<sup>nd</sup> ed. New York: Cambridge University Press; 2005
- [23] Rajkumair, S., Natesan, A., and Srinivasain, N. Penta-Band Hybrid Fractal MIMO Antenna System for ISM Applications”, *Inter., Journal of RF and Microwave Computer-Aided Engr*, 2018; 28(2): 1-13
- [24] Rappaport, T. S. *Wireless Communications*. 2<sup>nd</sup> ed. USA: Prentice Hall; 2002.
- [25] Odeyemi., K and Ogunti., E (2014). Performance Comparison Of Beamforming And Multiplexing Techniques Using Smart Antenna Array, *I.J. Wireless and Microwave Technologies*, , vol.3, pp. 36-50

## Authors' Profiles



**Akande Olukunle Akande** obtained his B. Tech (2008) in Electronic and Electrical Engineering from Ladoke Akintola University of Technology Ogbomoso in 2008. M. Eng in Communication Engineering in 2013 and a PhD in Communication Engineering in 2019 from University of Ilorin and LAUTECH, Ogbomoso, respectively. He is a Lecturer at Federal University of Technology Owerri. His research interests include Mobile Wireless Communications and Resource Management in Cognitive Radio networks. He is a member of the Nigerian Society of Engineers (NSE) and Council for the Regulation of Engineering in Nigeria (COREN).



**Cosmas Kemdirim Agubor** has obtained B.Eng, M.Eng and PhD degrees. He is a registered member of the Nigerian Society of Engineers (NSE) and the Council for the Regulation of Engineering in Nigeria (COREN). He was an Engineer with the Nigerian Telecommunications Limited (NITEL) and rose to the rank of an Assistant Manager. He is now a lecturer in the Department of Electrical and Electronic Engineering, Federal University of Technology, Owerri, Imo State, Nigeria. His research area is in wireless communication with special interest in Antenna systems and diversity



**Olusola Kunle Akinde** received his MEng and Ph.D degrees in Computer and Electronic Engineering at the Federal University of Technology, Owerri, Nigeria. He is a Certified Engineer from the Council for Registration of Engineering in Nigeria, a member of the Nigerian Society of Engineers, a Member of Institute of Electrical Electronic Engineering (IEEE), in USA. He is currently a Lecturer with the Department of Electrical and Electronic Engineering, First Technical University, Ibadan, Nigeria. Areas of his research interests include real-time embedded and distributed systems, intelligent systems, security and monitoring system





**Longinus Sunday Ezema, Ph.D** is a senior lecturer and passionate student mentor with about 10 years of postgraduate experience at a leading university in Nigeria. His current research focus is on the application of electronic and communication engineering skill to provide solution to health challenges. He is part of the team that won the Hardware Cup competition organized by ITDi Nigeria in February, 2020. His team was the first runner up at Alphalab Gear International Hardware Cup competition in USA. He is currently working on Humanoid Tele-Robotic Medical Care System to Combat Disease and Mortality in Isolated Areas of Africa



**Samuel Okechukwu Okozi** received his B. Eng, in Electrical and Electronic Engineering from the Federal University of Technology Owerri (FUTO). He obtained M. Eng and Ph.D in Electrical Engineering at University of Nigeria Nsukka (UNN). He is a Senior Lecturer in the Department of Electrical and Electronic Engineering at the Federal University of Technology Owerri, Nigeria. He is a registered member of Nigerian Society of Engineers (NSE), and Council for the Regulation of Engineering in Nigeria .

**How to cite this paper:** Akinyinka Olukunle Akande, Cosmas Kemisdin Agubor, Olusola Kunle Akinde, Longinus Sunday Ezema, Samuel Okechukwu Okozi, " Development of a New Diversity Scheme in 5G Network at 28 GHz Millimeter-wave Frequency for Digital Mobile System", International Journal of Wireless and Microwave Technologies(IJWMT), Vol.11, No.1, pp. 47-62, 2021.DOI: 10.5815/ijwmt.2021.01.05